

1689/1690

MONTAGEANLEITUNG ASSEMBLING INSTRUCTIONS INSTRUCTIONS D' ASSEMBLAGE

- * Sortieren Sie zuerst die Teile z.B. 1, 2 und mit Hilfe der " Liste der Beschläge " die Einzelbeschlagteile , z.B. A , B , usw. heraus .
- * Dann beginnen Sie mit der Vormontage wie wir Ihnen in den einzelnen Montageschritten , 1, 2 usw. nachfolgend demonstrieren .
- * Check all parts in accordance with list printed overleaf . All major parts identified thus A, B, etc. , 1, 2 , etc resp.
- * Vérifier toutes les parties d'après la liste ci-après . Toutes les parties principales sont marquées A, B , etc. , 1, 2 , etc. respectivement .
- * Assemble in the sequence shown 1, 2 , etc.
- * Procéder au montage successivement 1, 2 , etc.

BENÖTIGTES WERKZEUG TOOLS REQUIRED OUTILS NÉCESSAIRES



ACHTUNG !!! Auf jeden Fall nach Anleitung montieren .
ATTENTION !!! Please assemble exactly as per instruction .
ATTENTION !!! Veuillez assembler en suivant les instructions.

LISTE DER BESCHLÄGE LIST OF PARTS PIÈCES DE QUINCAILLERIE

A (E701000) 61x 8x30	B (E701153) 30x 15 mm	C (E701231) 46x	D (E701149) 16x 12 mm
E (E701010) 16x 6x40	F (E700900) 90x 1,8x25	G (E700000) 11x 4x15	H (E704476)
J (E702016) 16x	K (E700140) 16x 6,3x13	L (E700020) 28x 3,5x13	5x
M (E703107) 4x	N (E703108) 4x		
O (E705040) 8x	P (E705071) 8x	Q (E710106) 4x 120 mm	
	R (E703408) 8x	S (E710107) 4x 242 mm	
T (E700060) 10x 3,5x17	U (E700570) 16x M4x25	V (E702008) 8x	W (E709606) 12x
X (E707616) 4x 334 mm		Y (E706300) 4x 8x1,5	a (E709318) 1x
			b (E700700) 2x

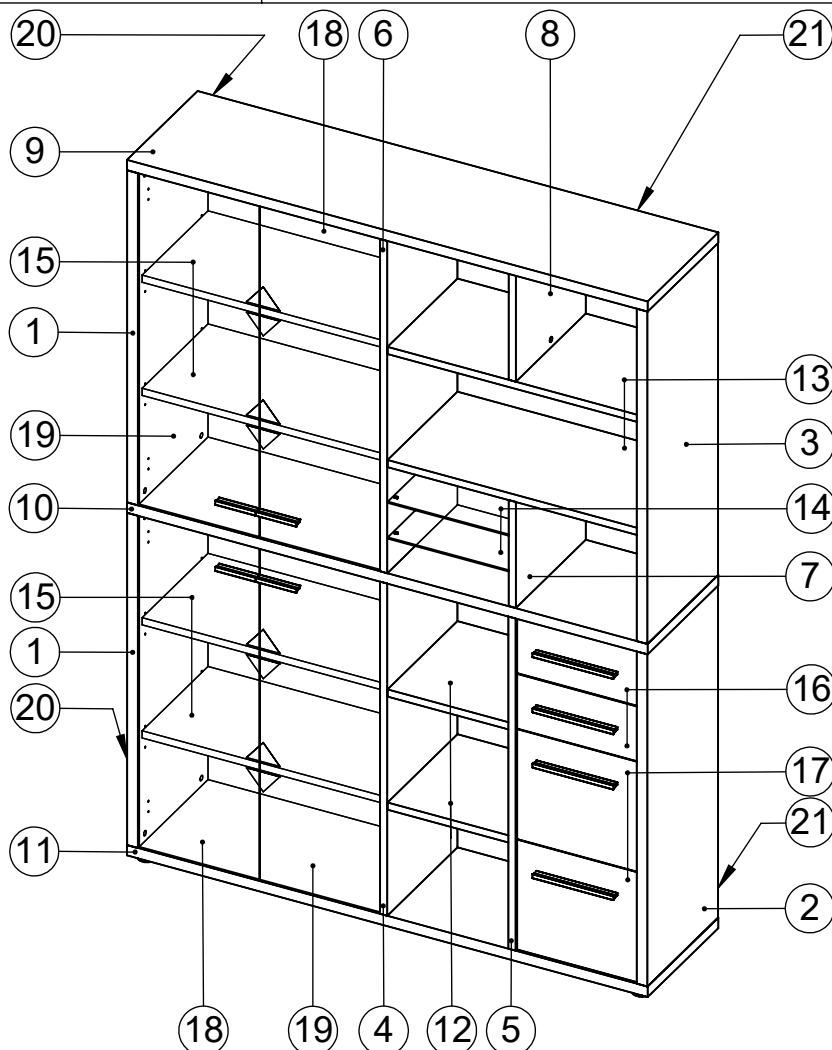

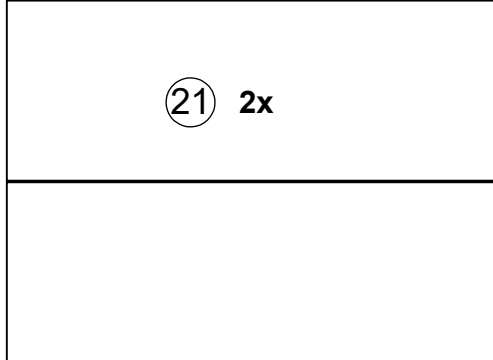
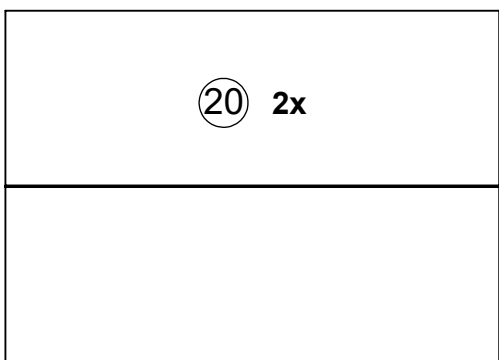
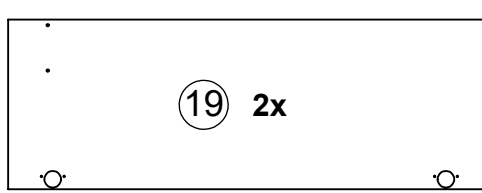
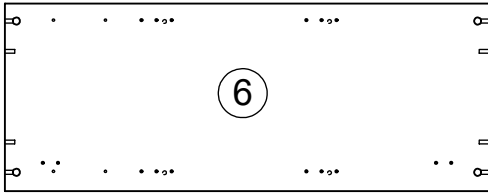
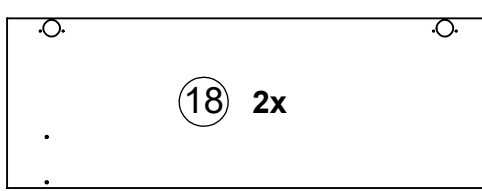
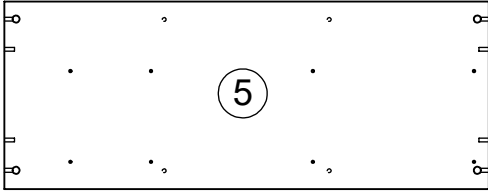
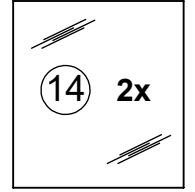
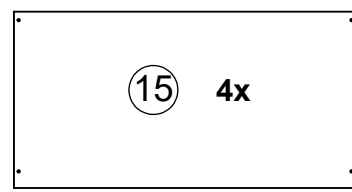
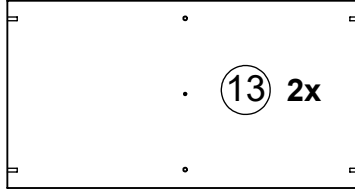
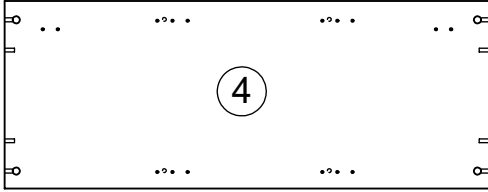
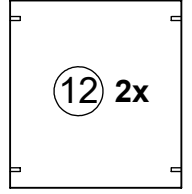
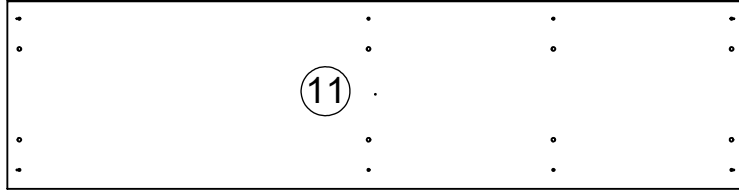
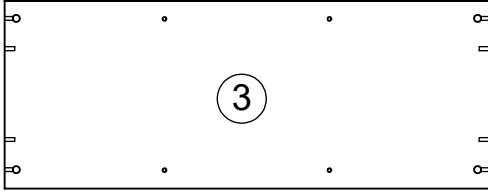
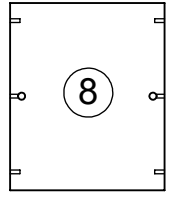
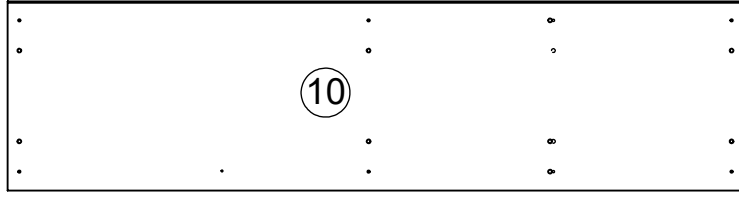
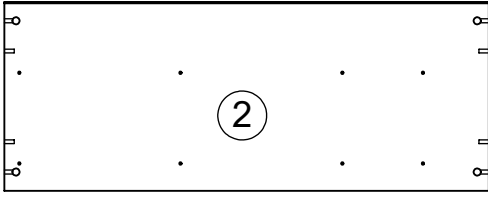
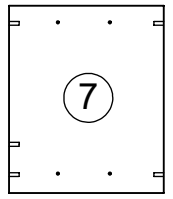
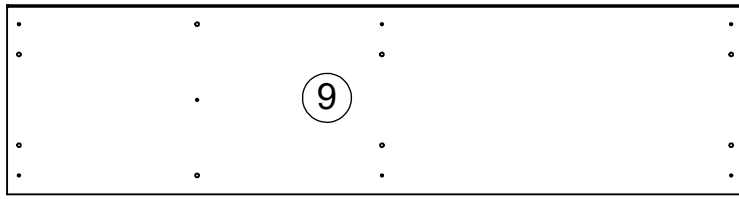
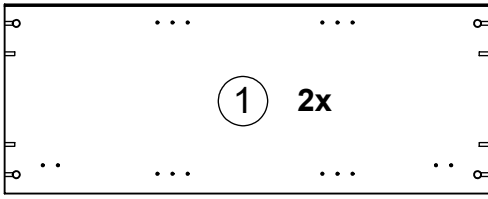

16 2x

22 2x

23 2x

24 2x

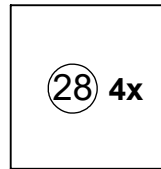
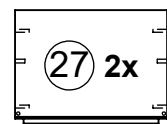
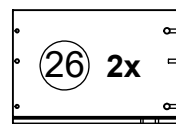
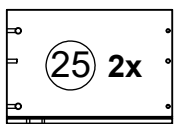
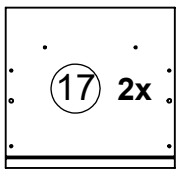
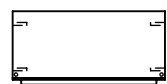
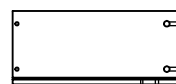
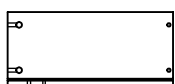
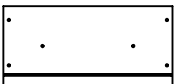

1

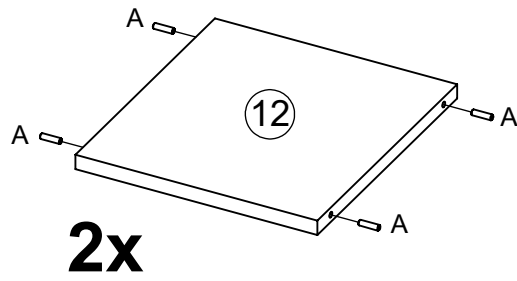

2

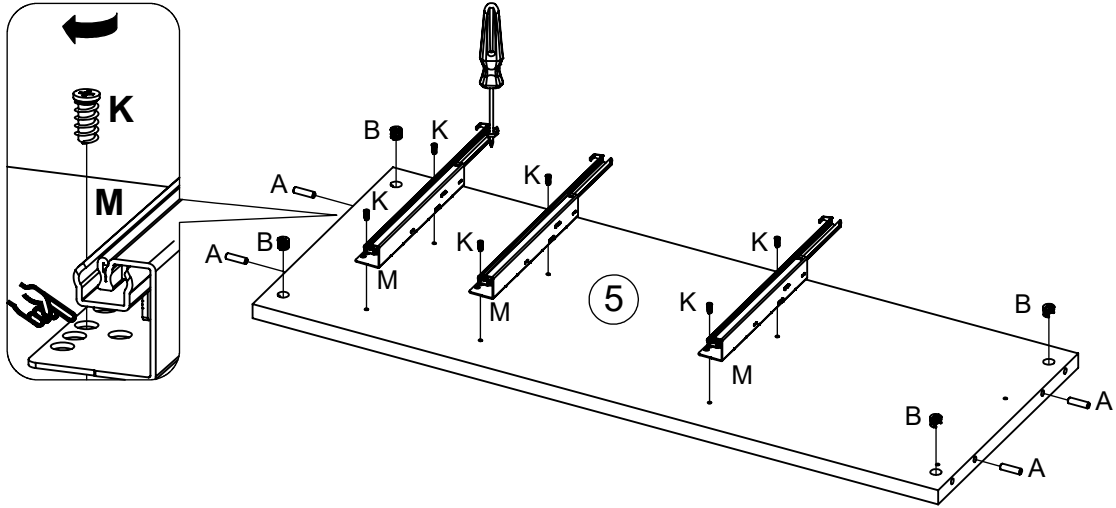

3

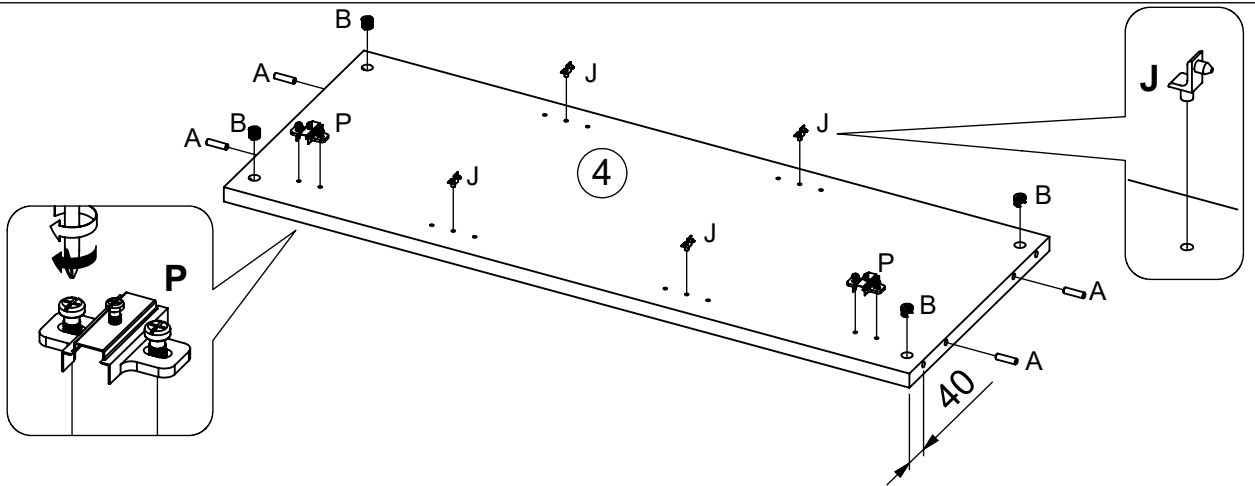

4

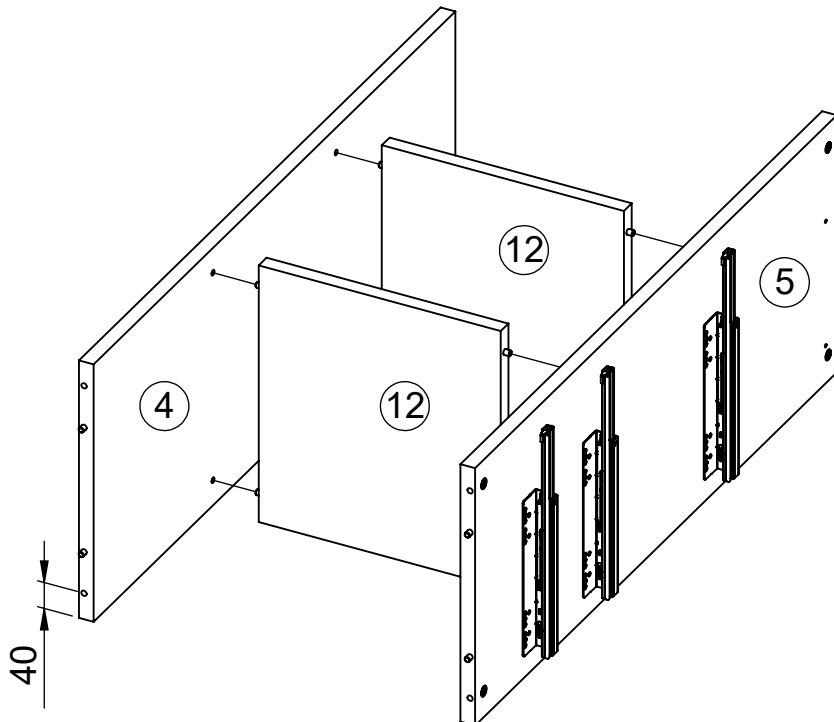

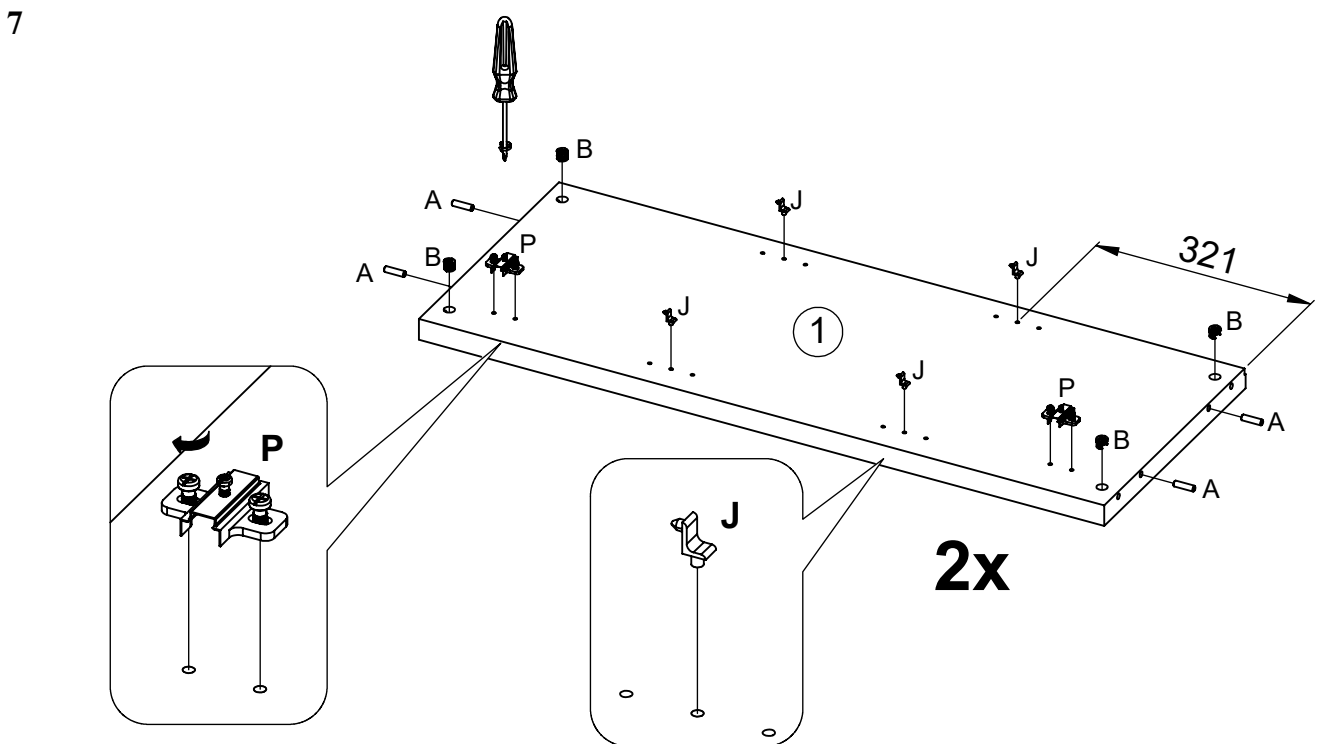
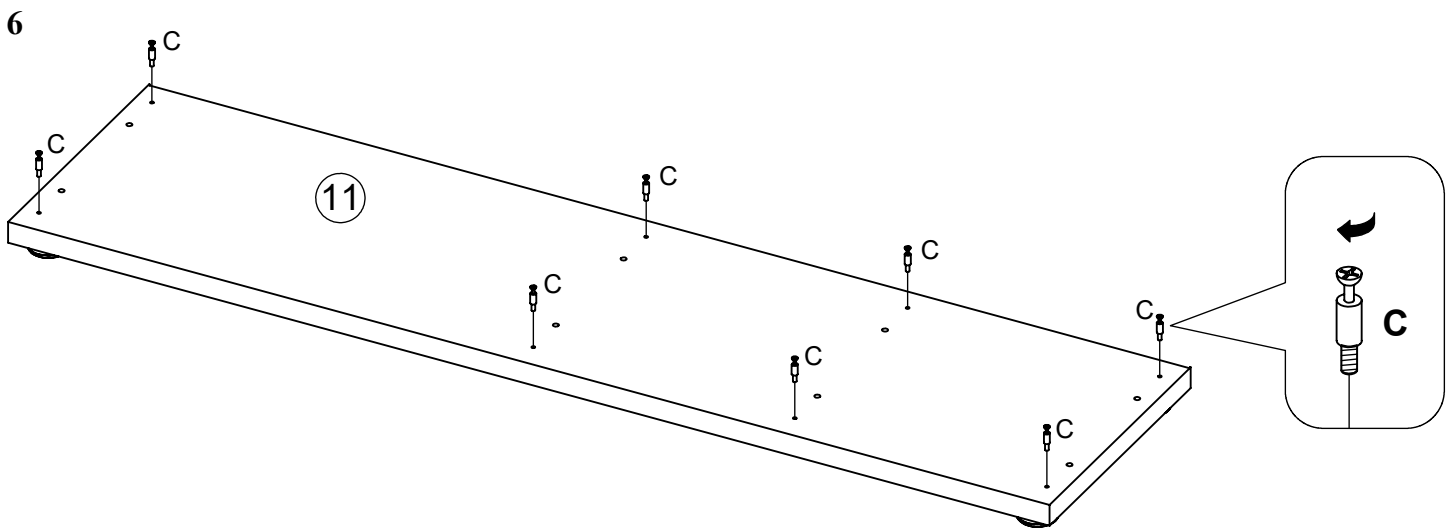
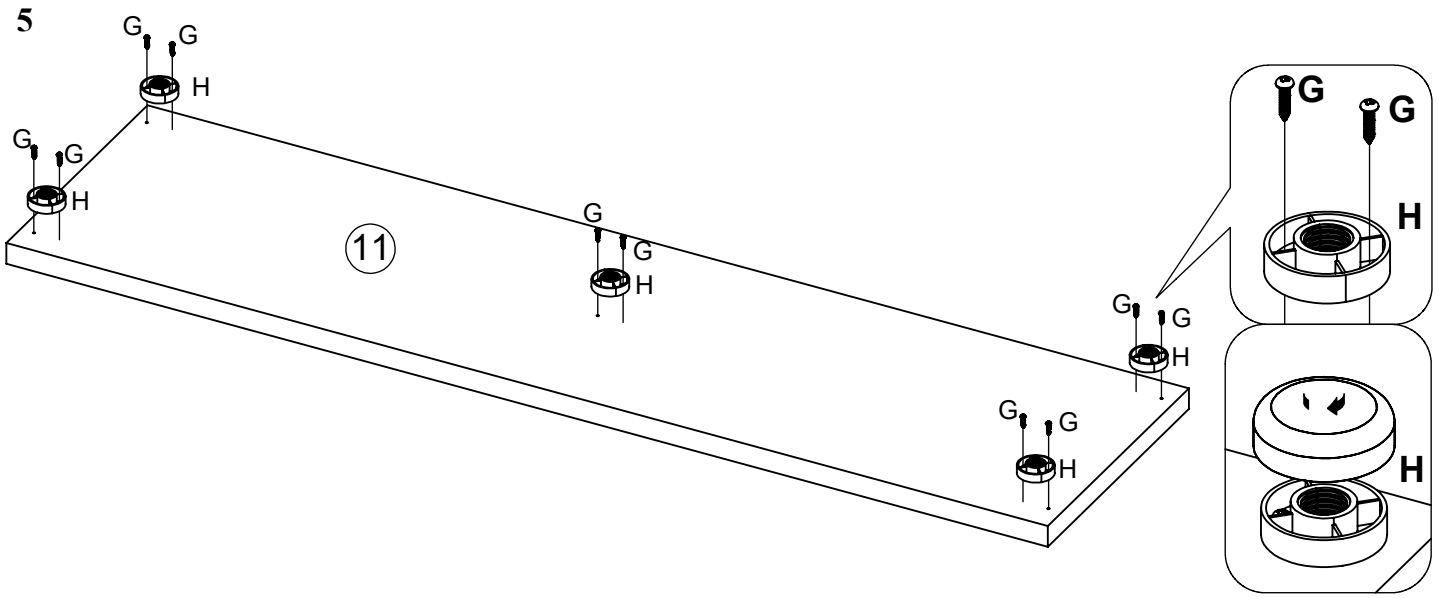

8

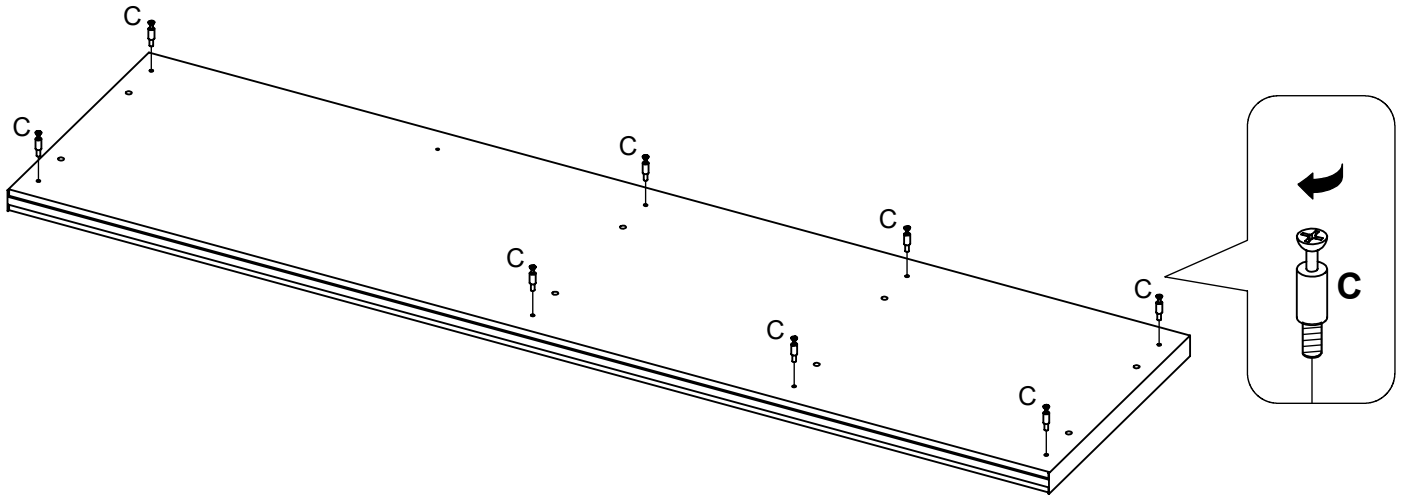

9

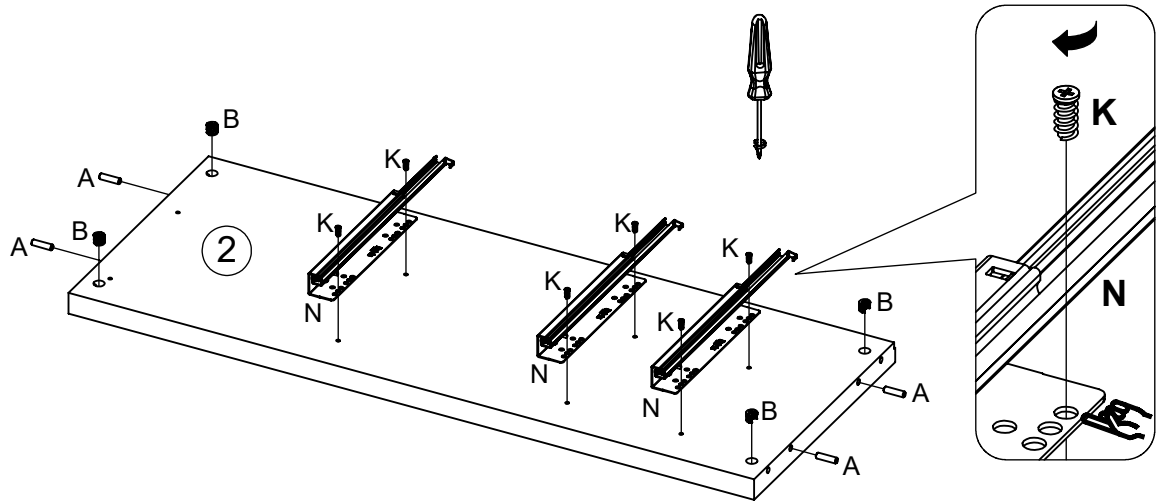

10

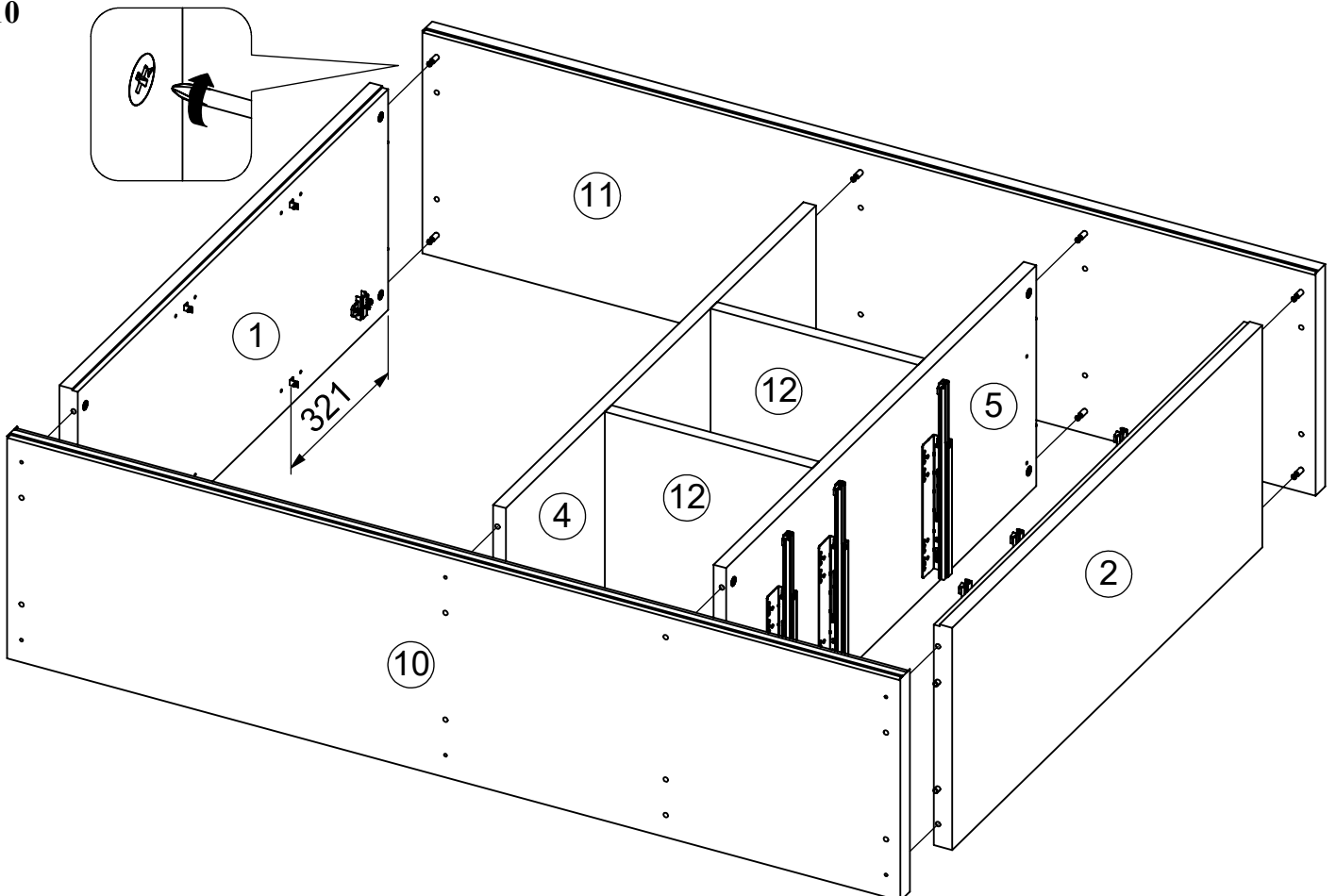

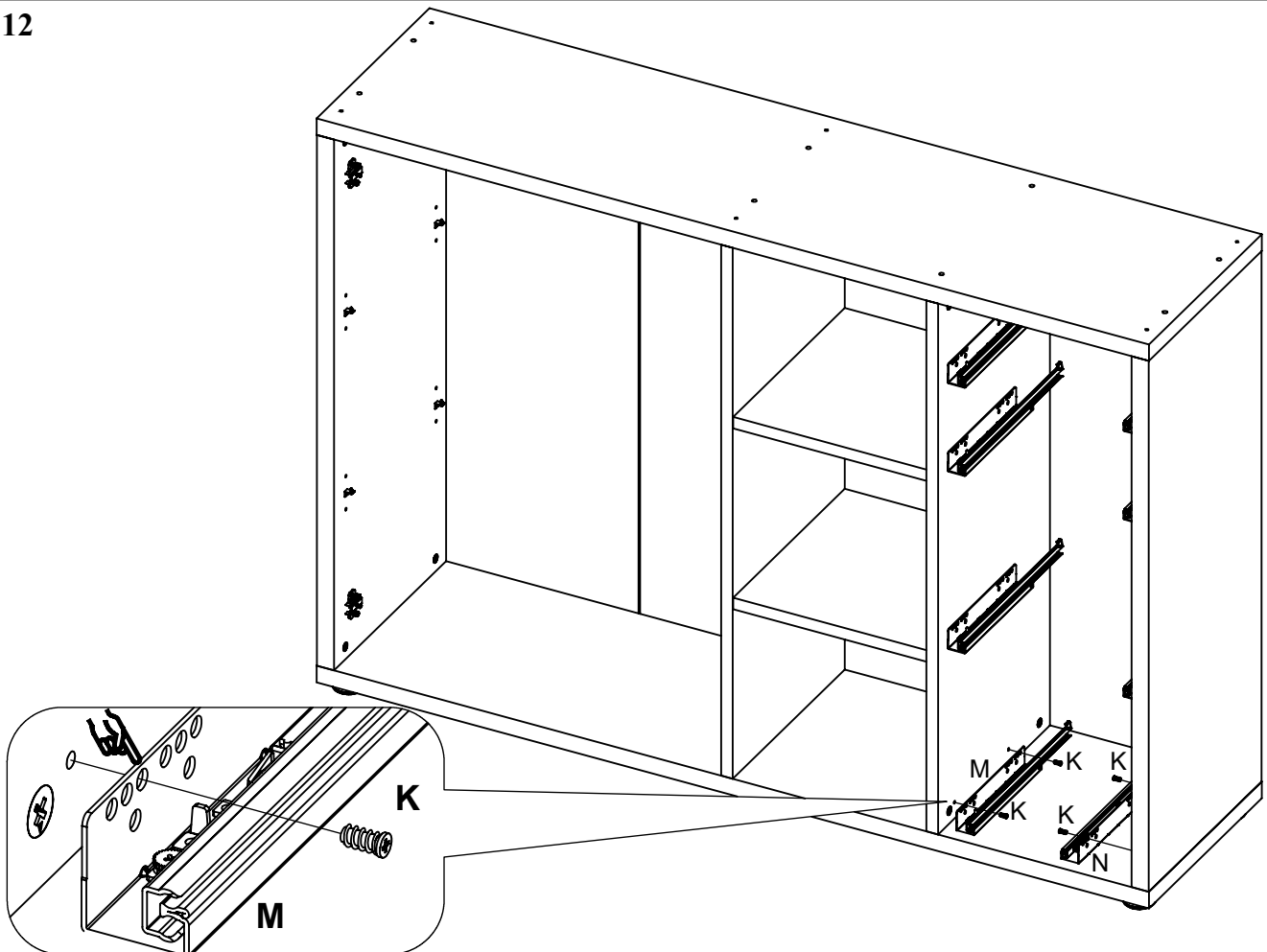
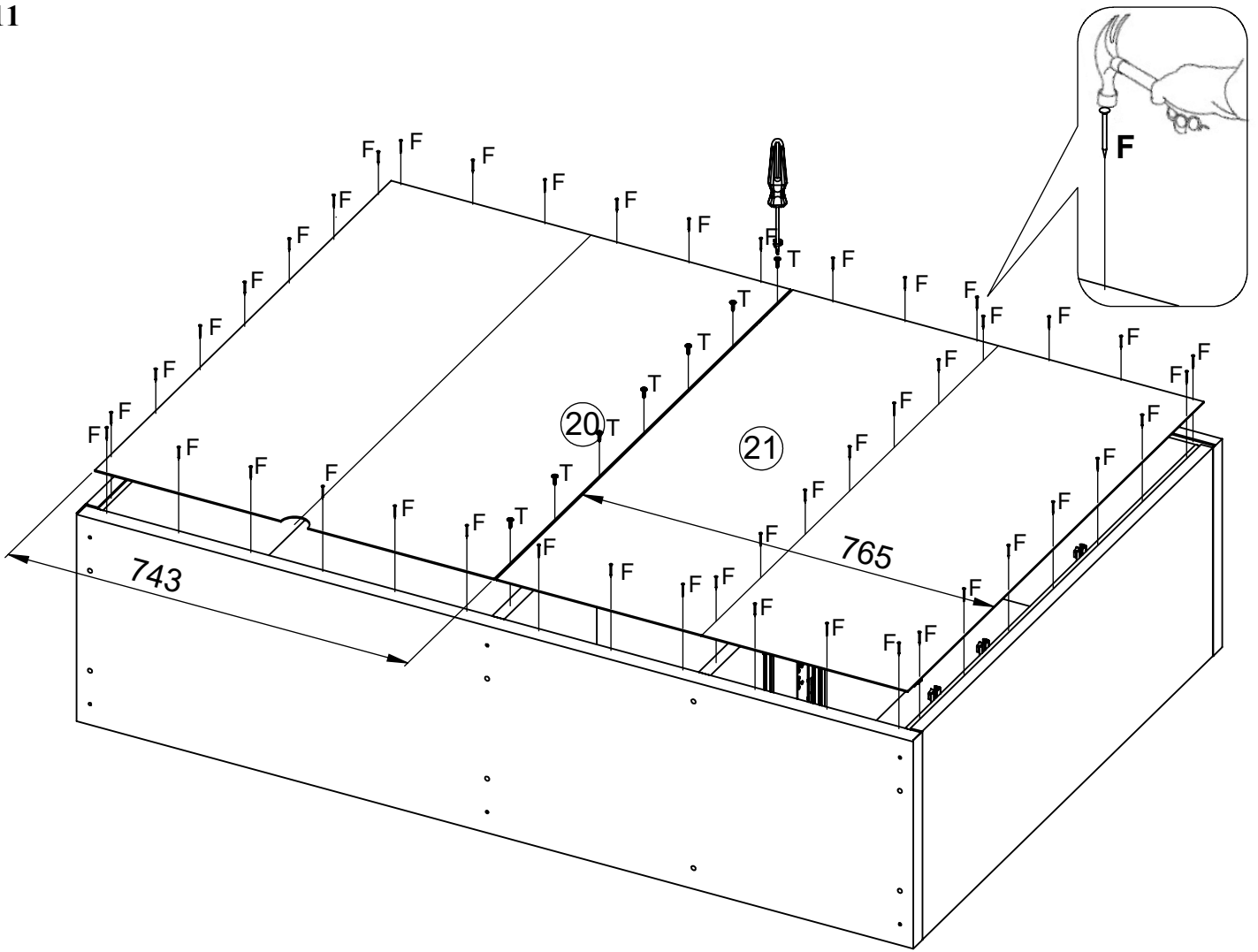

13

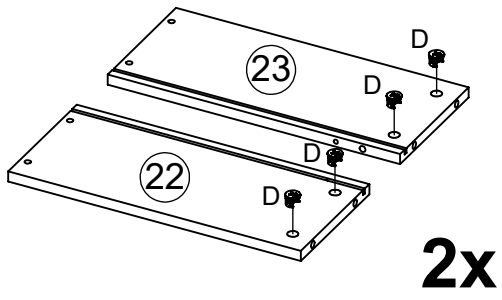

14

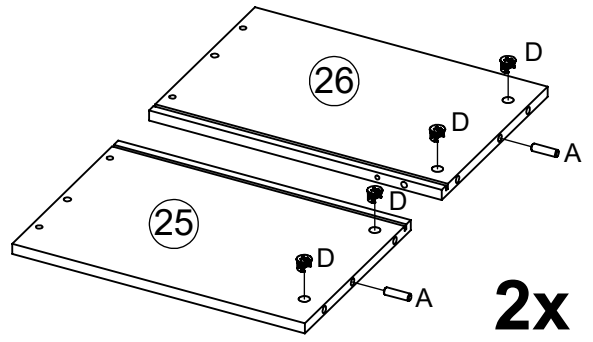

15

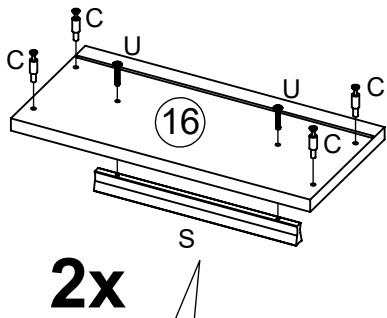

16

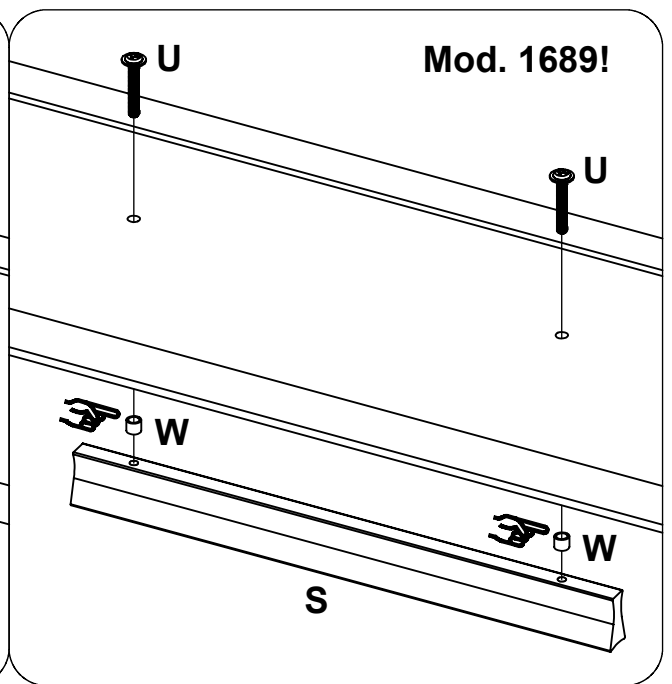
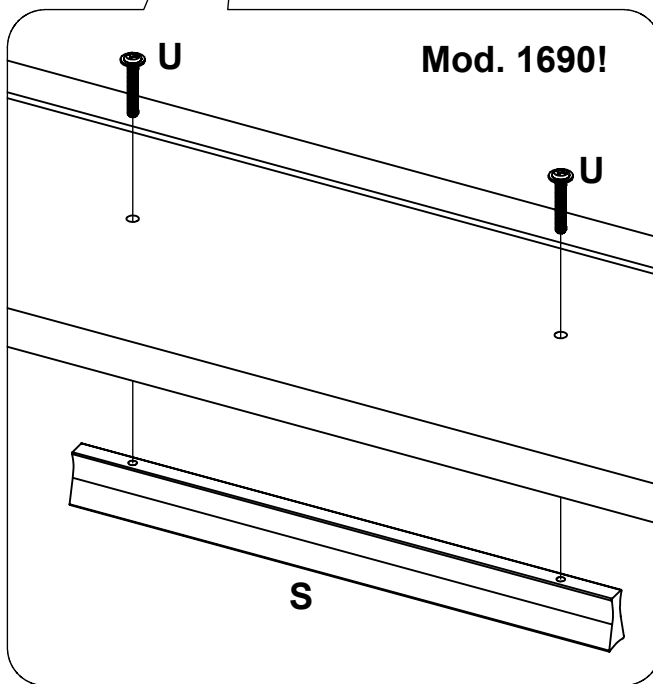
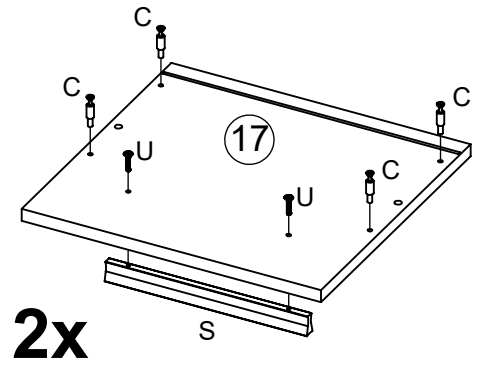

17

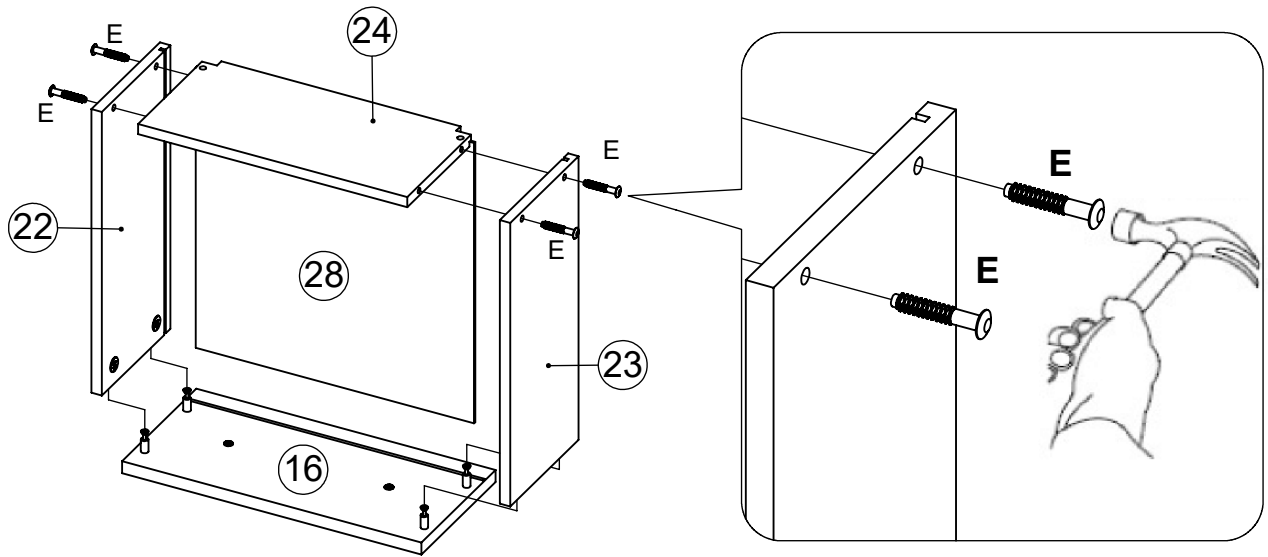

2x

18

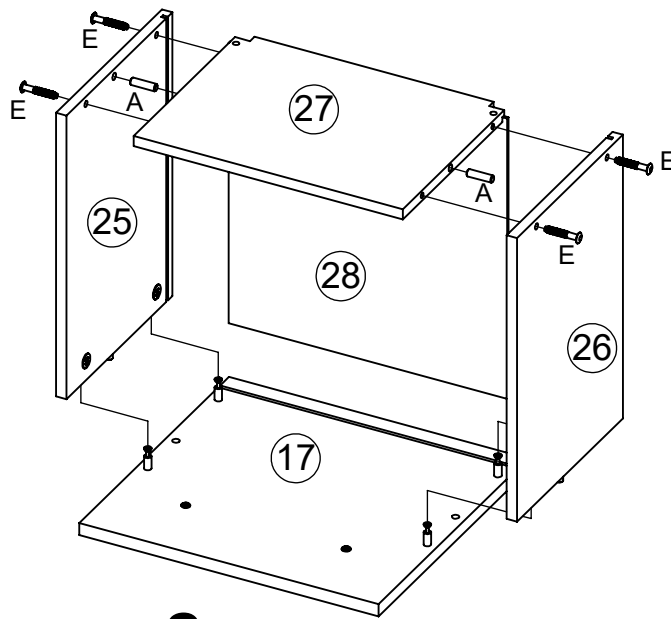

2x

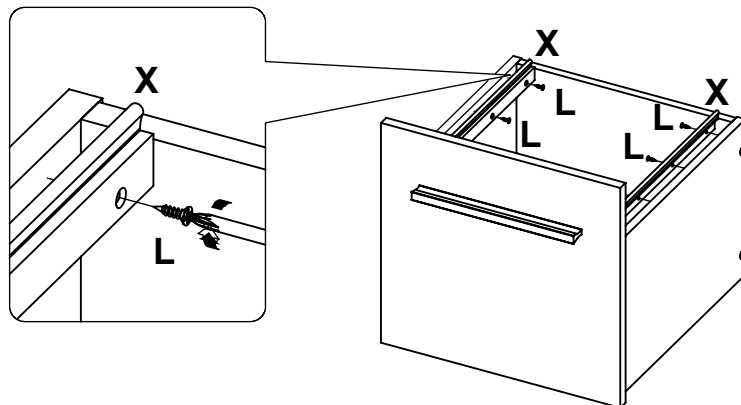

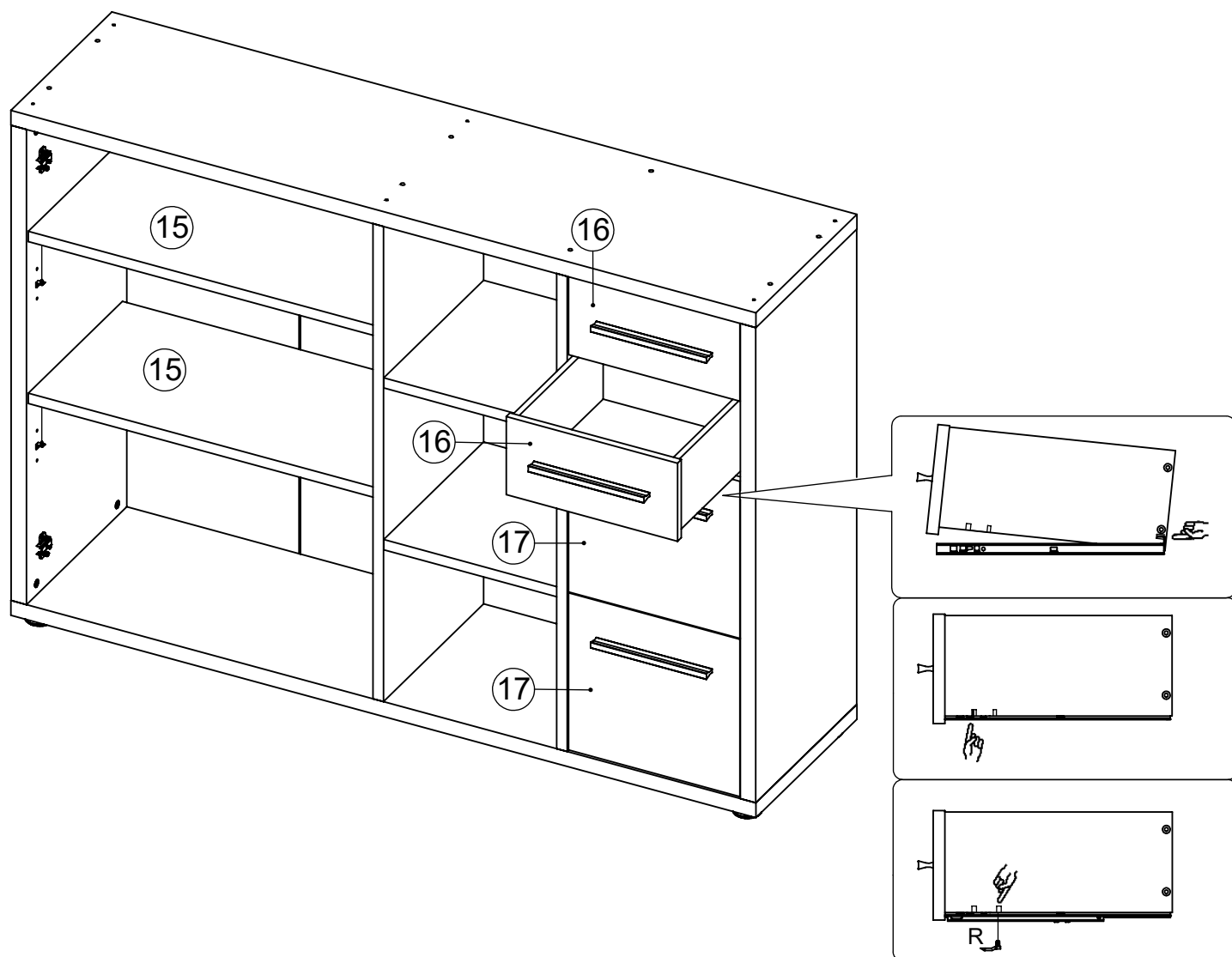

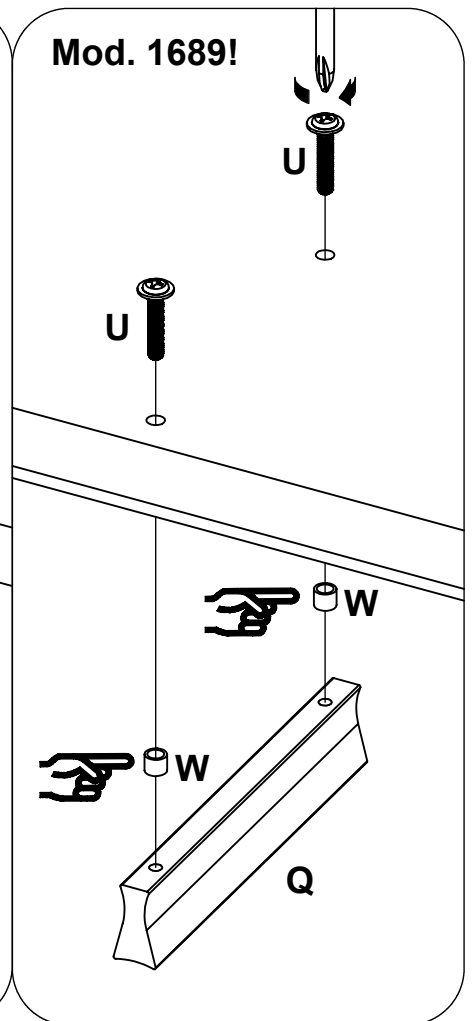
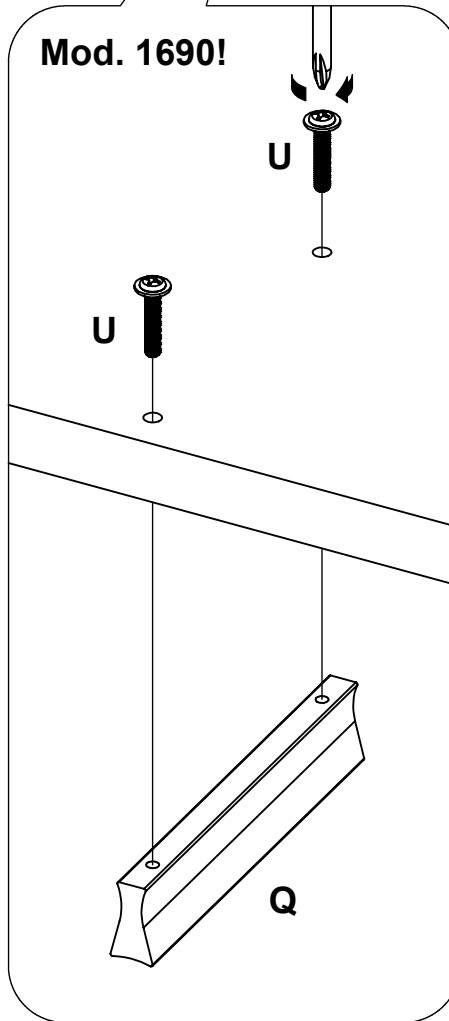
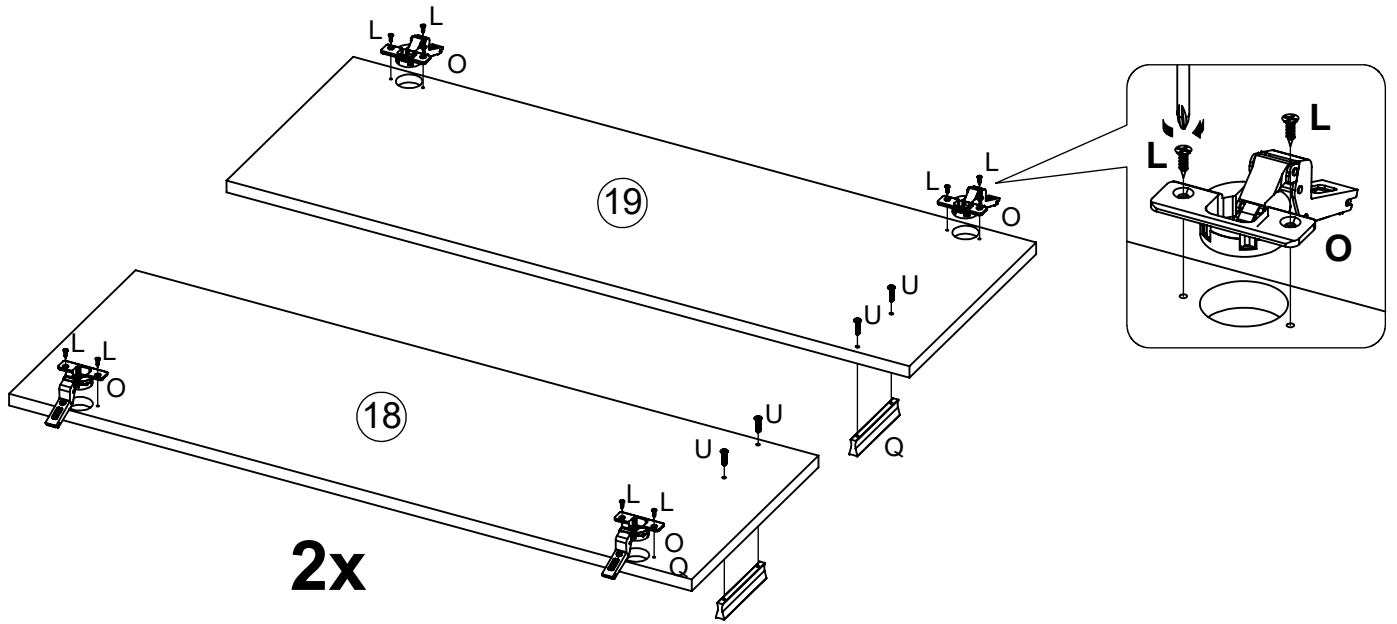

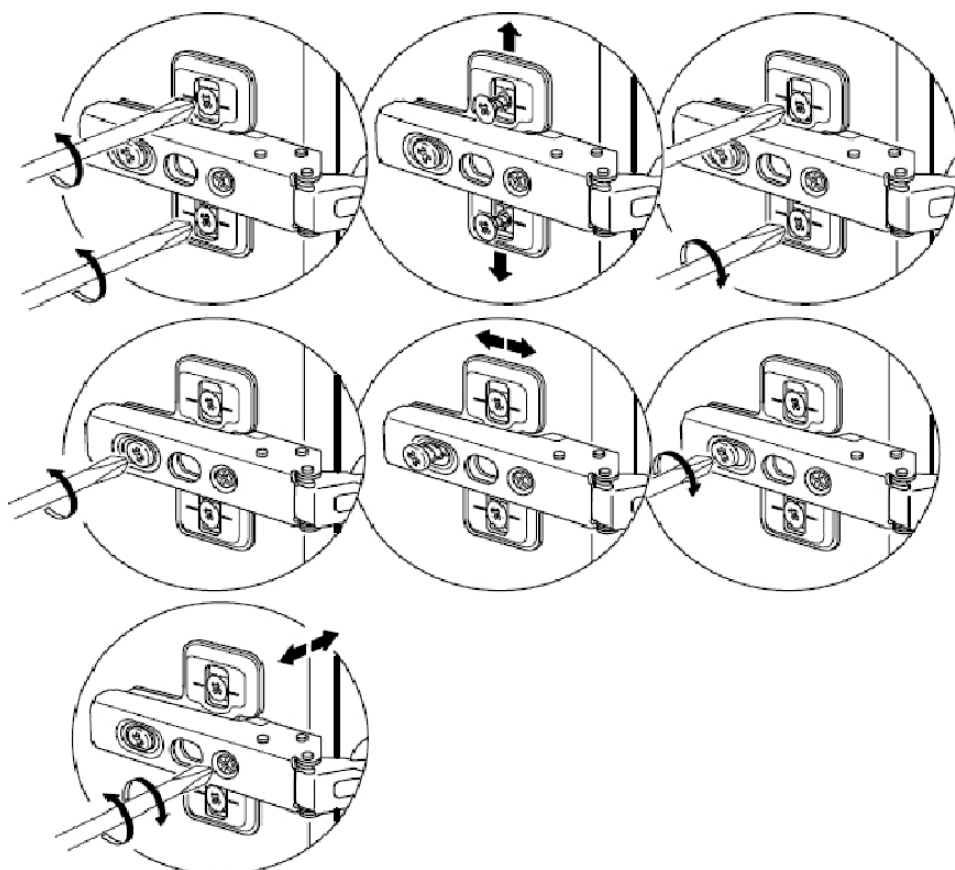
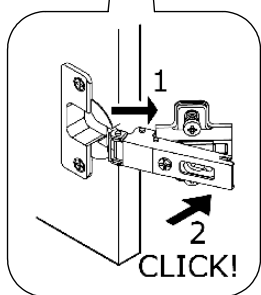
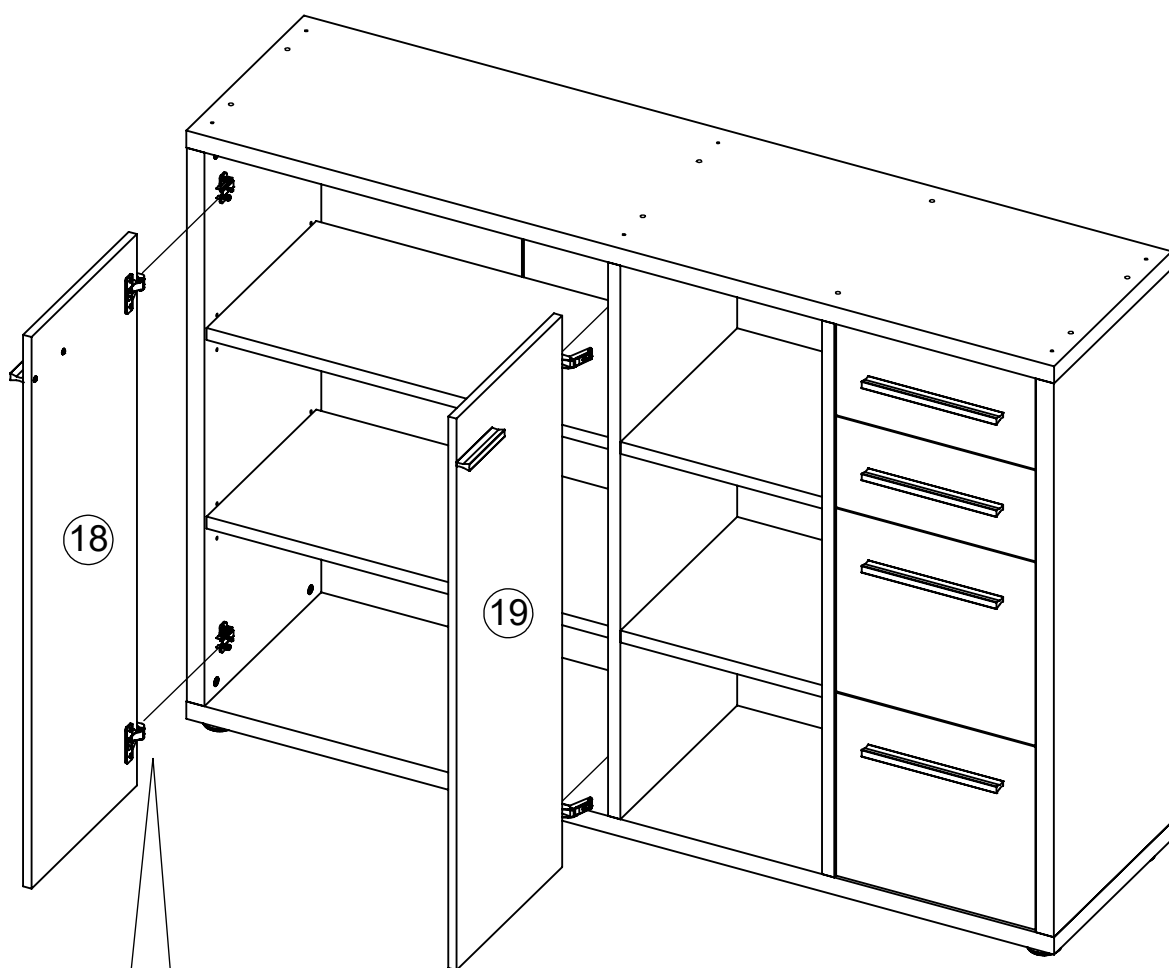

22

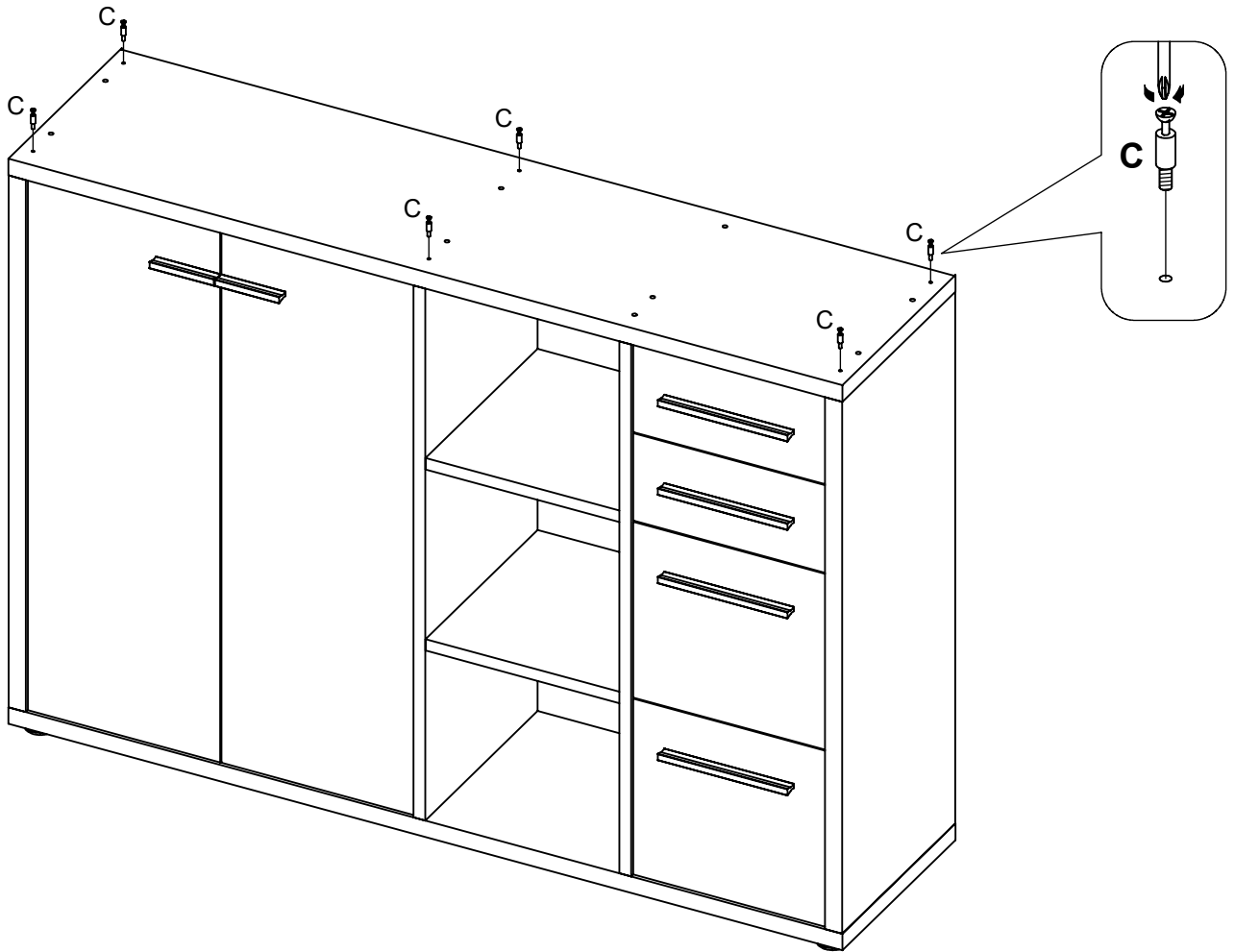

23

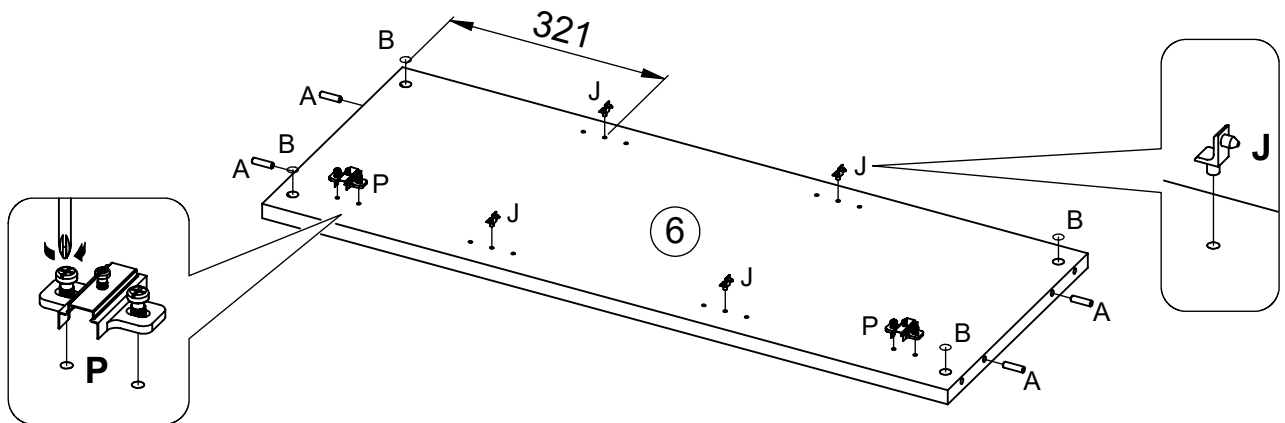

24

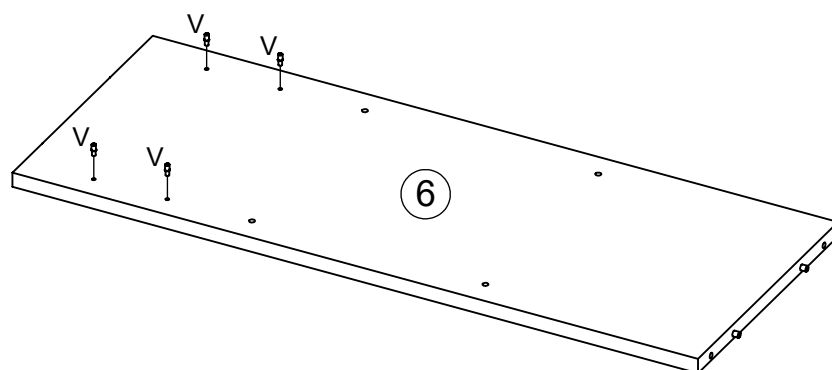

25

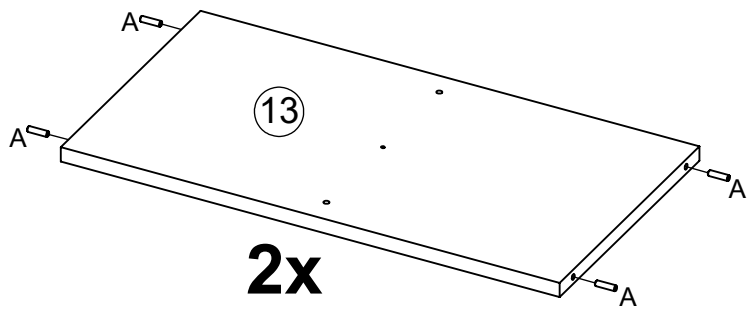

27

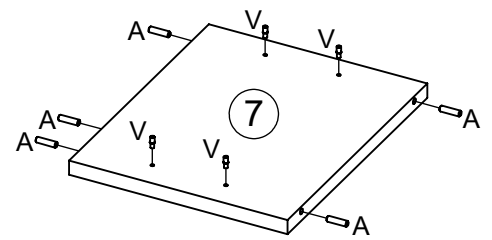

26

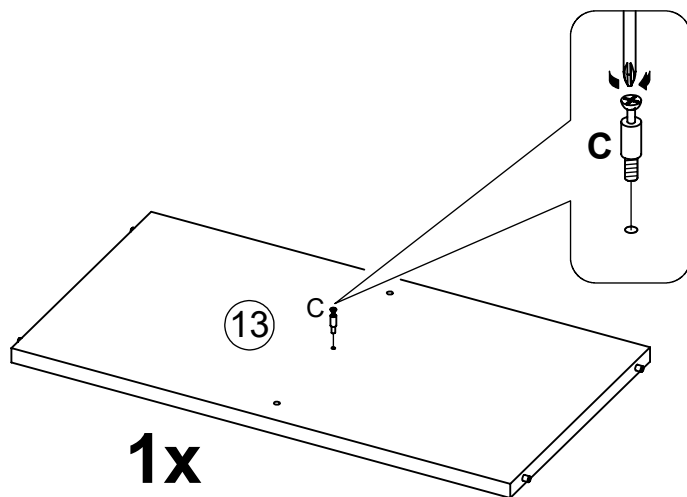

28

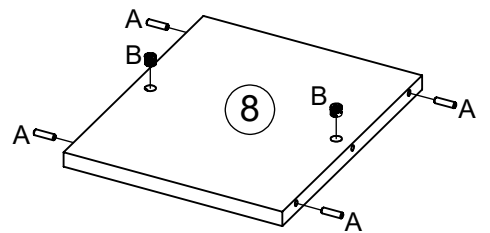

29

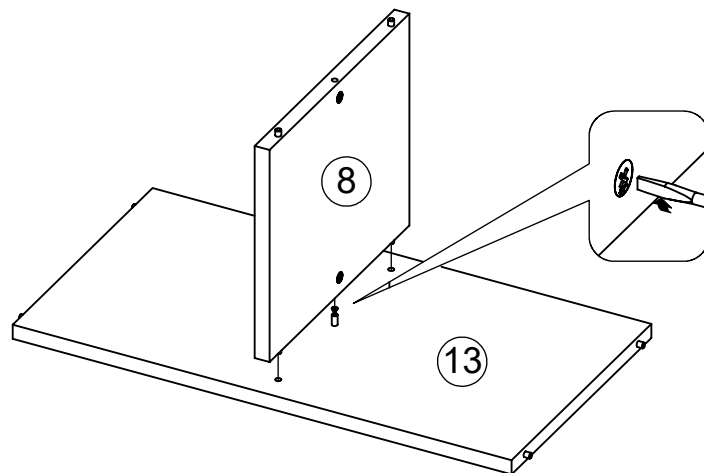

30

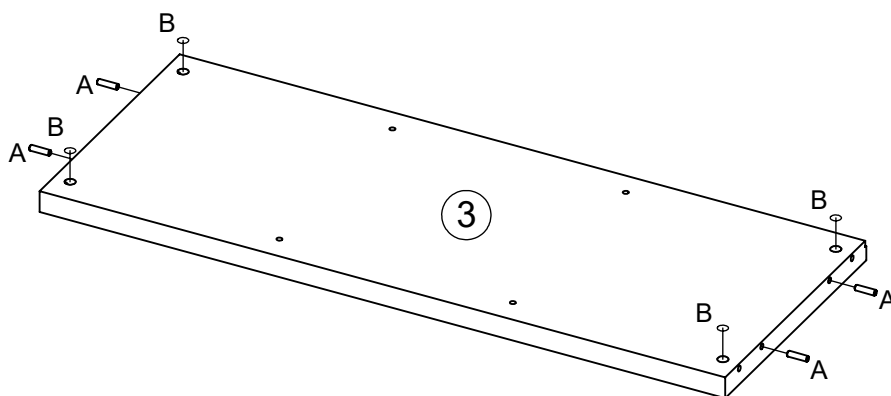

31

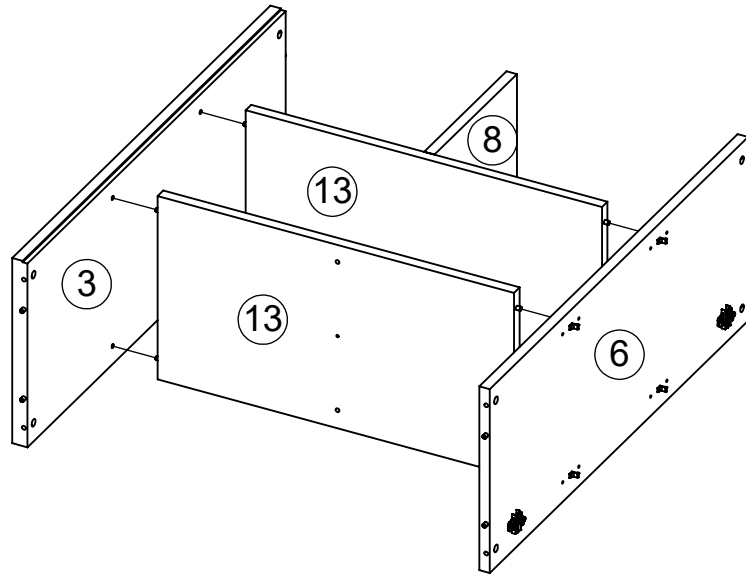

32

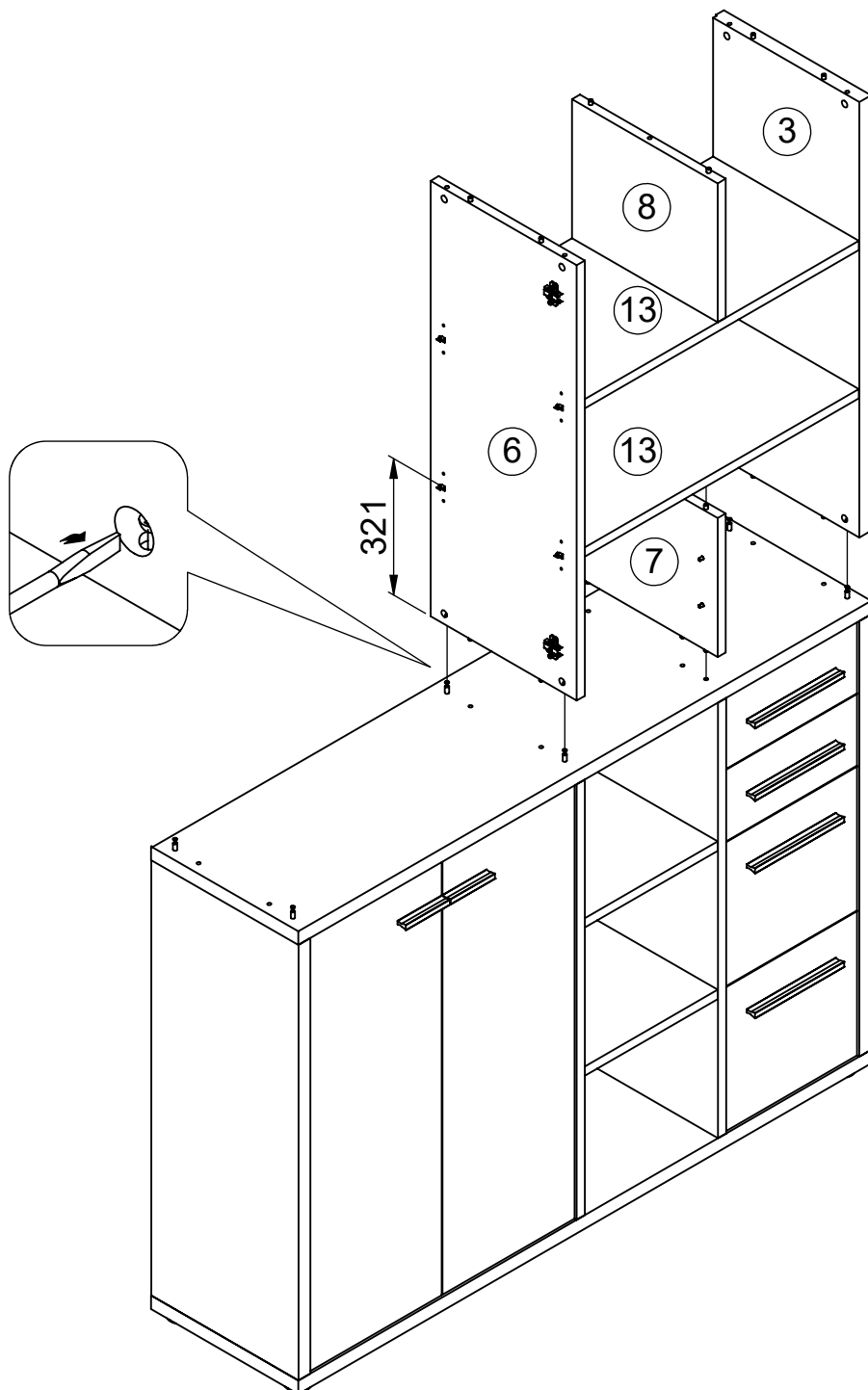

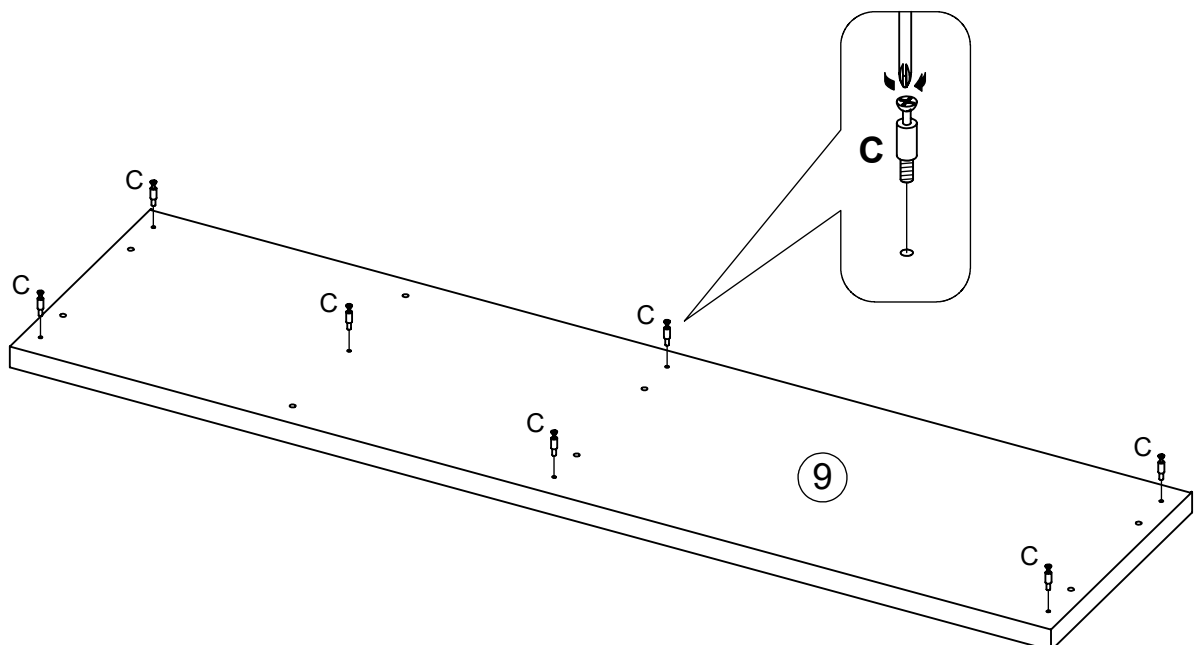
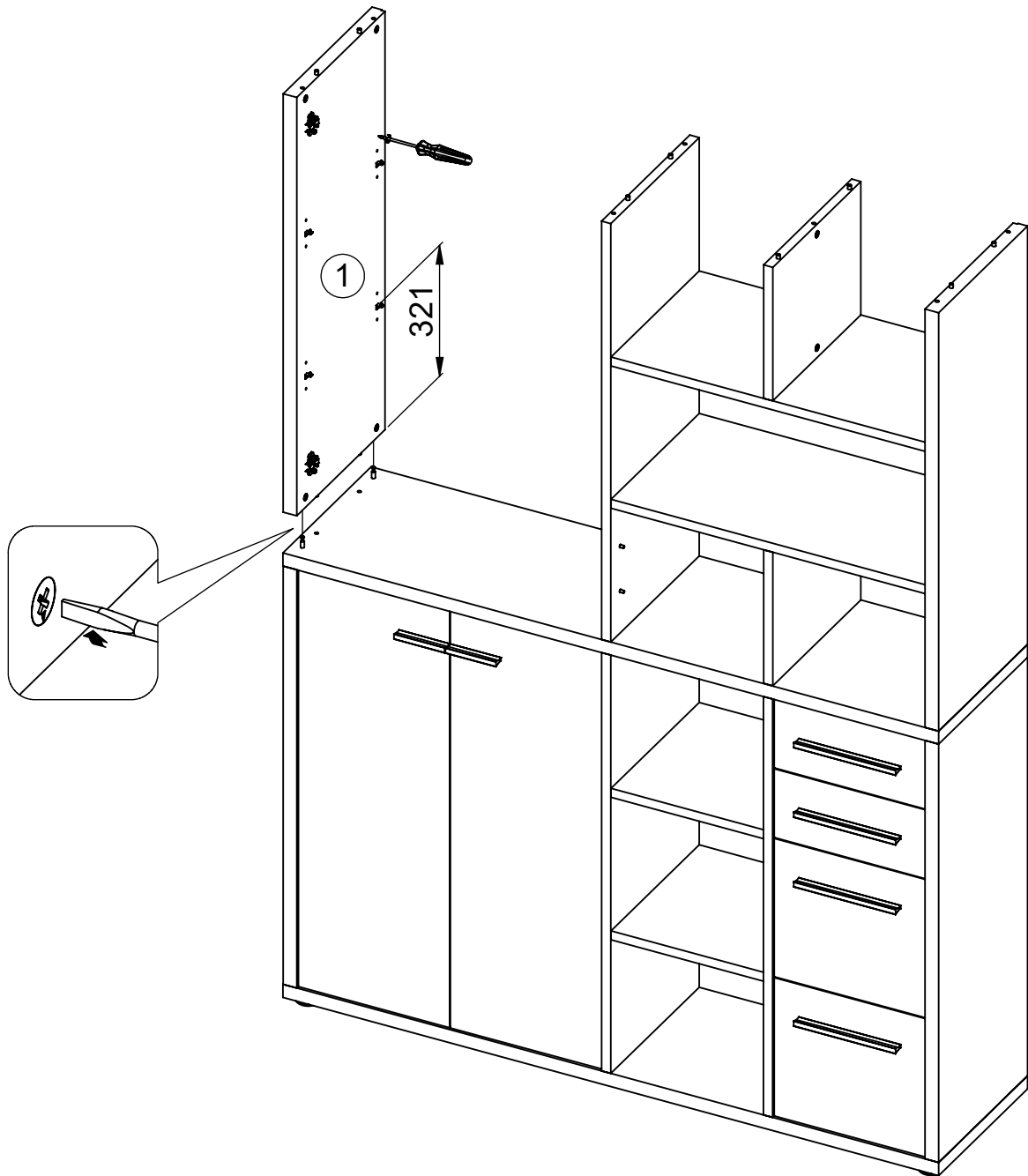

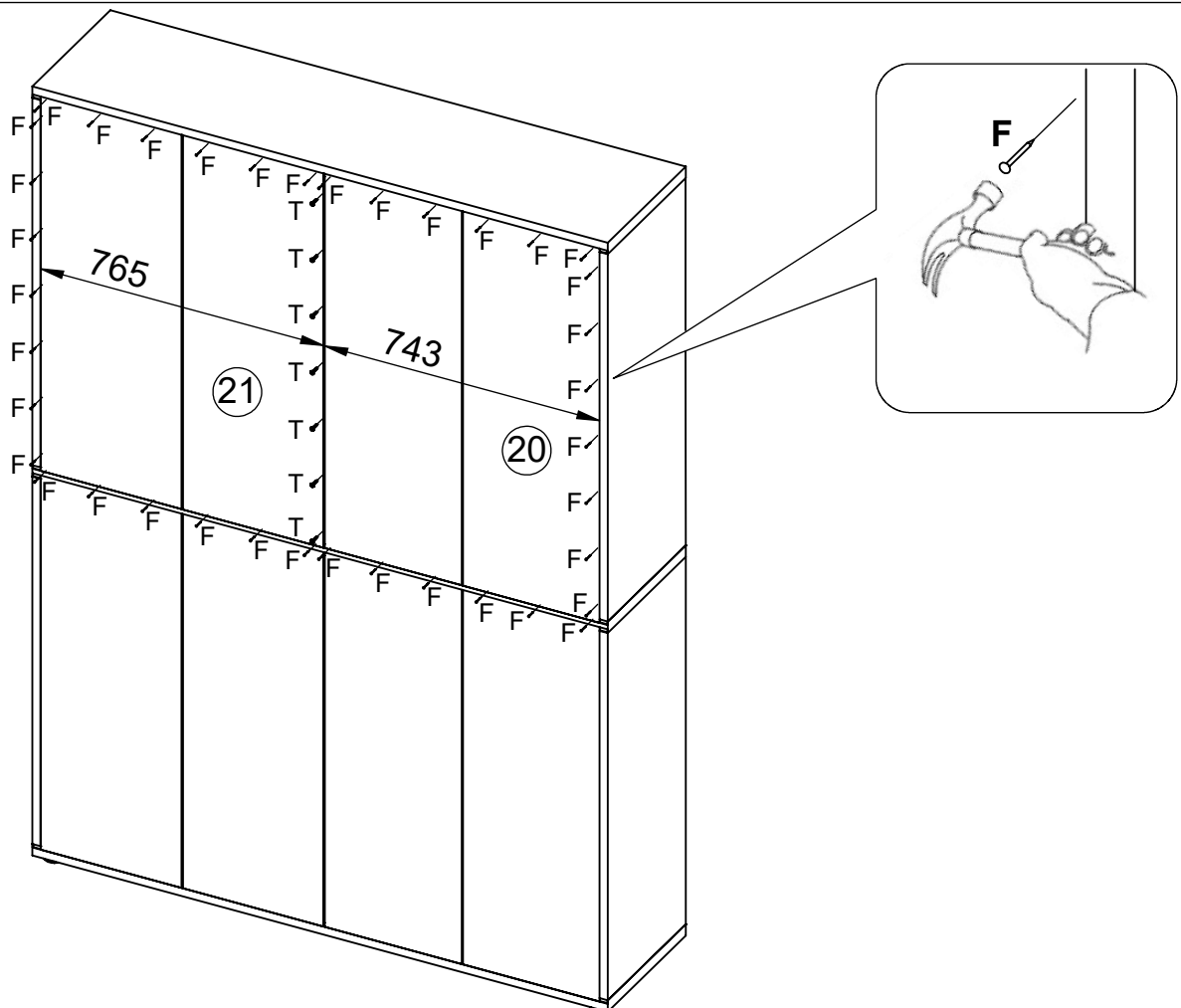
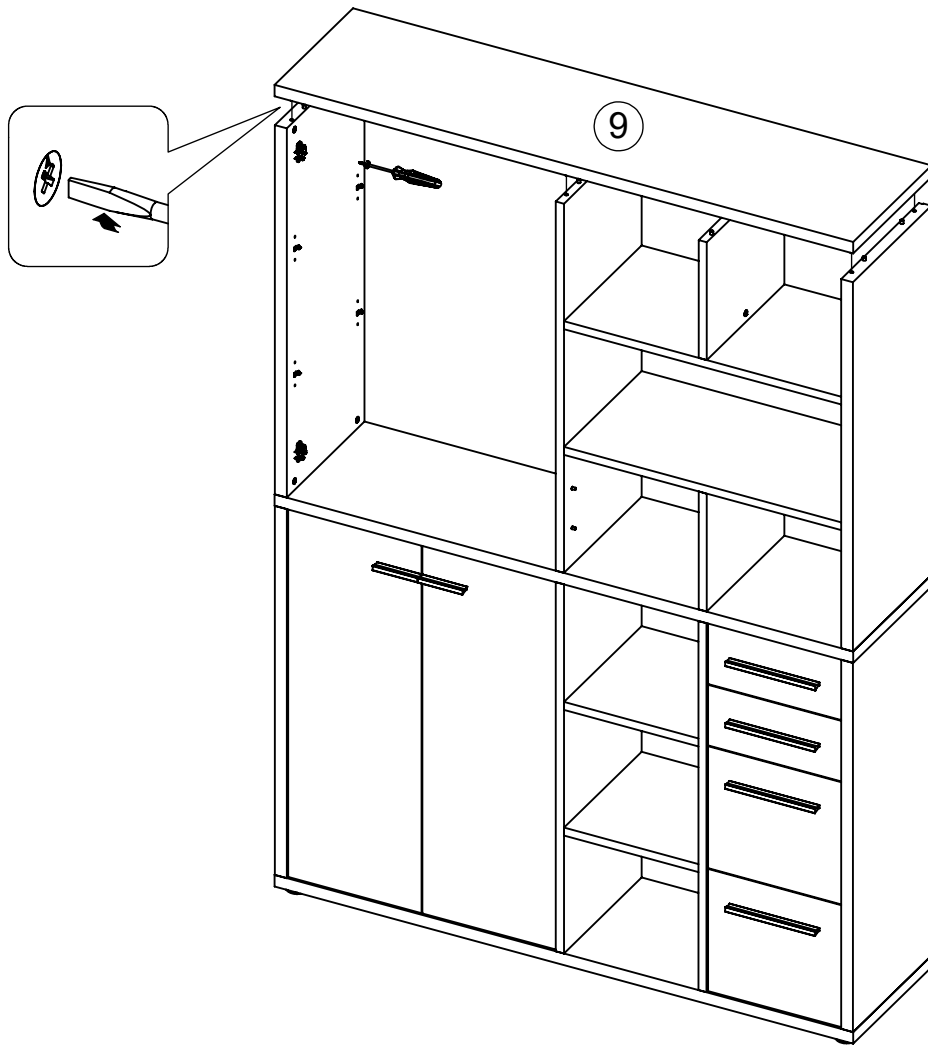

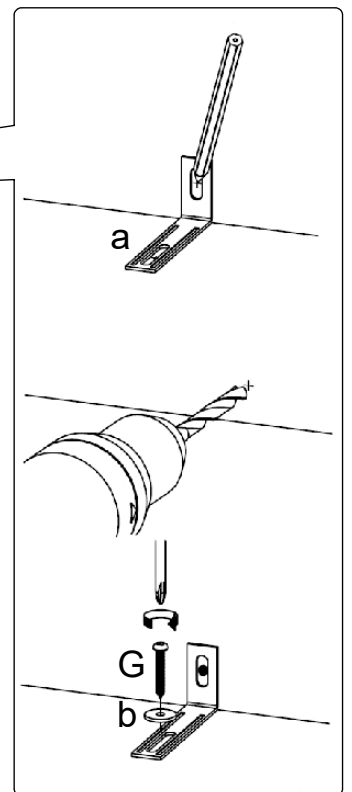
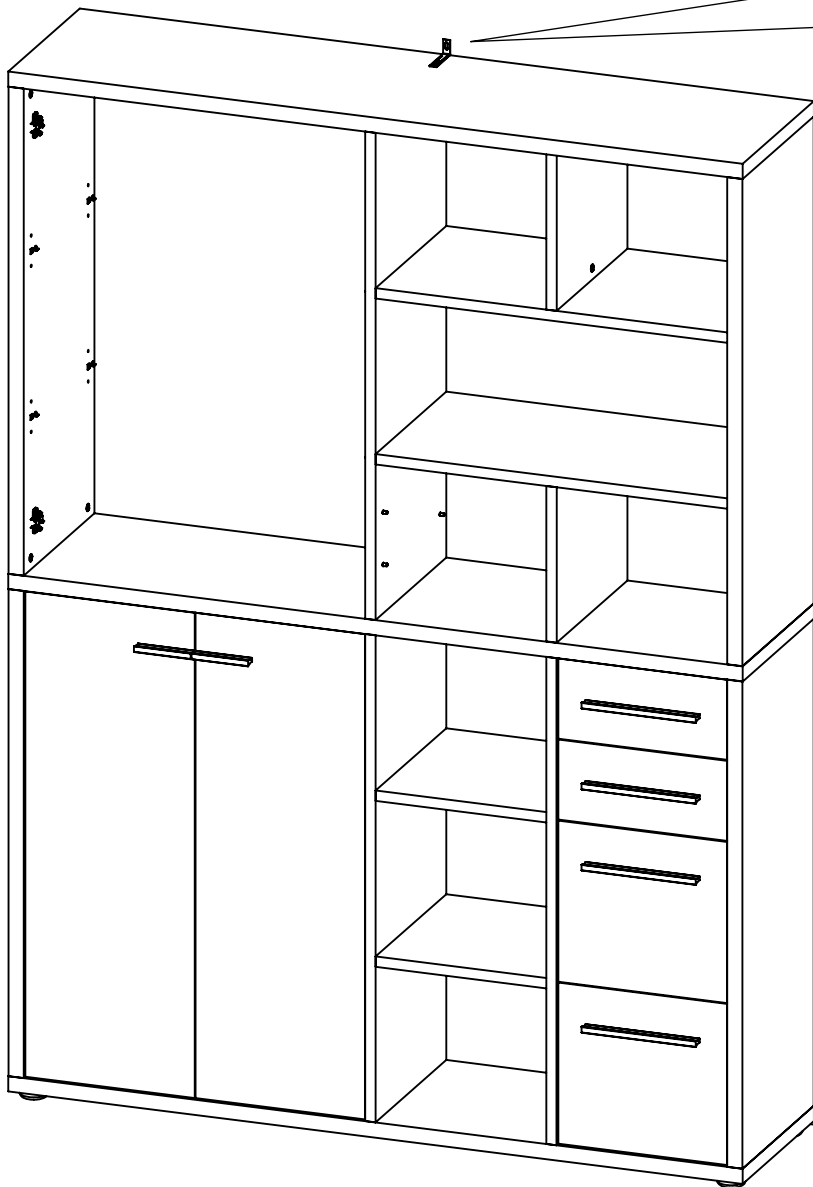
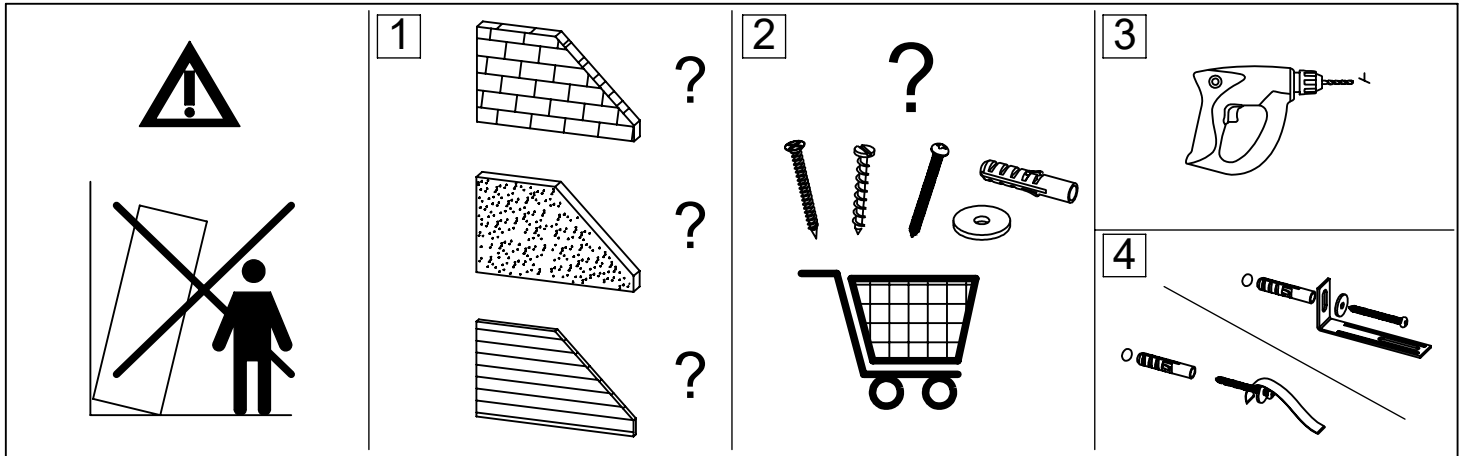

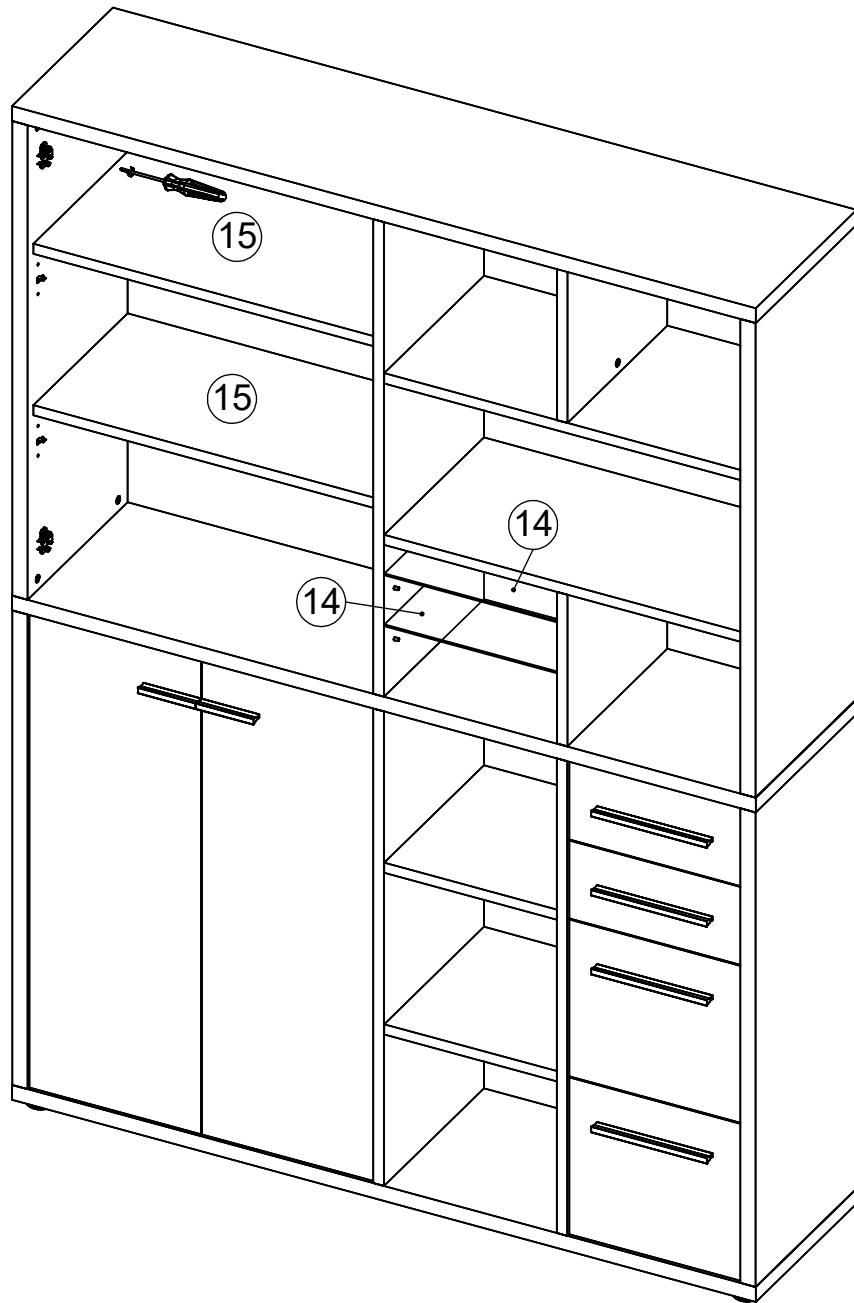

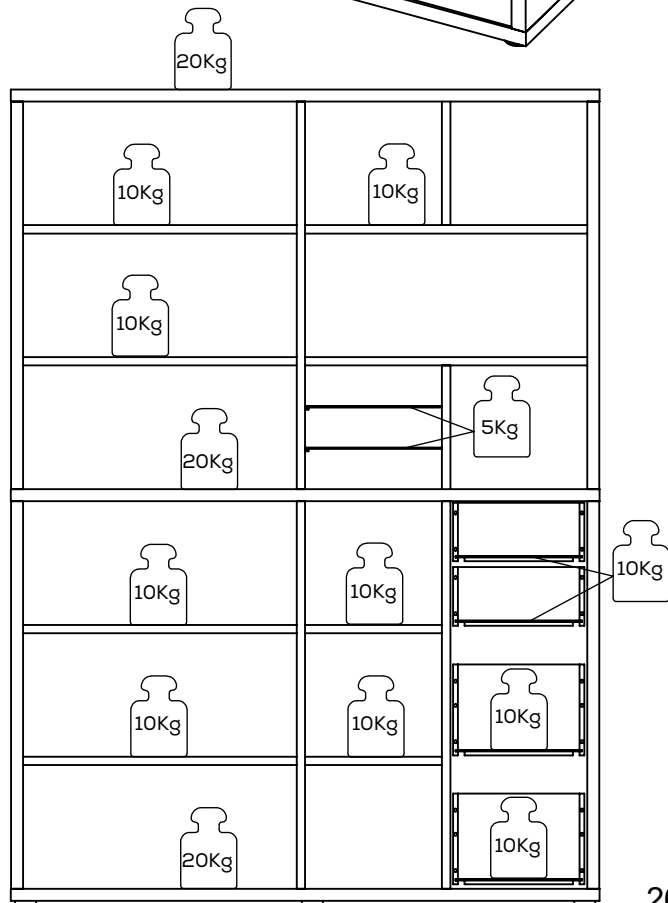
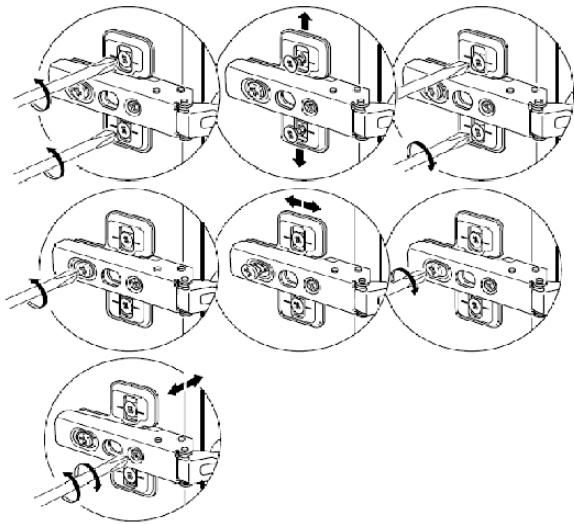
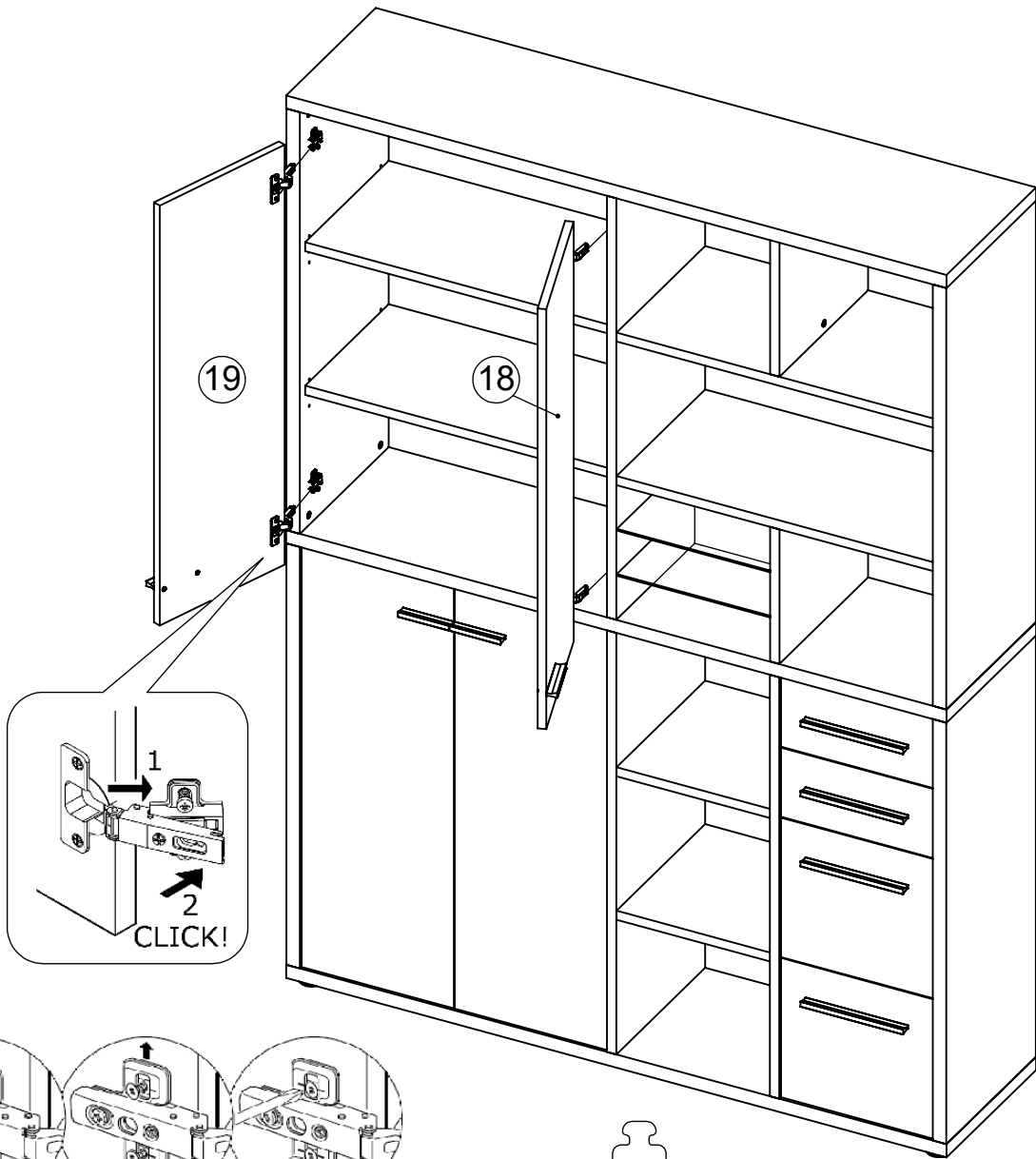

1689

Serviceblatt, Bitte für evtl. Ersatzteilbestellung aufbewahren

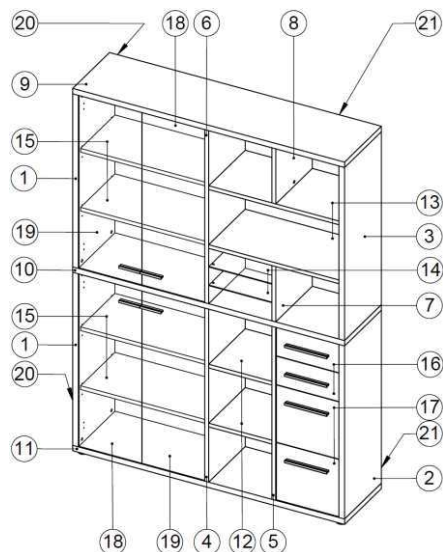

Sie haben sich für ein Qualitätsmöbel aus Deutscher Herstellung entschieden. Wir führen sehr umfangreiche Qualitätskontrollen nach ISO-Normen durch. Sollte der Artikel trotzdem Anlass zu einer Reklamation geben, bitten wir Sie die nachfolgenden Punkte zu beachten. So können wir Ihnen schnell und unbürokratisch helfen.

Ergänzen Sie die Artikelnummer durch die Farbnummer vom Etikett. Tragen Sie bitte auch die Kontrollnummer ein.

Artikelnummer 1 6 8 9 _ _ _ _

Kontrollnummer _ _ _ _ _

Zur Ersatzteilbestellung geben Sie bitte die Teilenummern an. (Bei Beschlägen die in Klammern stehenden Zahlen)

Geben Sie dieses Blatt an Ihr Möbelhaus weiter, damit wird eine schnellere Bearbeitung Ihrer Bestellung gewährleistet.

Service, please keep this sheet for possible order of replacement parts

Congratulations on your decision for a quality furniture Made in Germany. We do very extensive quality controls according to ISO norms. Should the article give cause to complaint anyway, we would ask you to pay attention to the following items, so we can assure quick and unbureaucratic help.

Please add the colour number - which is written on the label - to the code number and fill in the control number.

Code number: 1 6 8 9 _ _ _ _

Control number: _ _ _ _ _

For ordering a replacement part, please state the numbers of elements (in case of metal fittings the numbers in brackets).

Please pass this sheet on to your furniture shop. This ensures a quick treatment of your order.

Service après vente, veuillez garder cette feuille pour une commande éventuelle de pièces de rechange

Vous avez choisi, un meuble de qualité fabriqué en Allemagne. Nous vous félicitons pour votre décision. Nous réalisons des contrôles de qualités draconiens suivants les normes ISO. Malgré cela, si vous rencontrez un problème de SAV. Veuillez faire attention aux points suivants, pour une résolution rapide de ce problème.

Veuillez compléter le numéro d'article, avec le code couleur que vous trouverez sur l'étiquette collée sur le carton d'emballage. Veuillez également indiquer le numéro de contrôle.

Artikelnummer 1 6 8 9 _ _ _ _

Kontrollnummer _ _ _ _ _

Si vous commandez des pièces de rechange, veuillez indiquer les numéros des pièces.























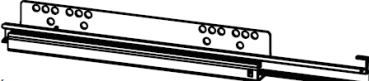
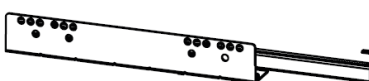



Si vous commandez des pièces de quincaillerie, veuillez indiquer les références entre parenthèses.

Veuillez remettre ce document, au magasin où vous avez acheté ce meuble afin que votre

Teilleiste

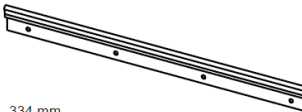
Nummer	Bezeichnung	Teilenummer	Stück
1	Seite links	03.135	2
2	Seite rechts	05.135	1
3	Seite rechts	05.134	1
4	Mittelseite	07.175	1
5	Mittelseite	07.176	1
6	Mittelseite	07.177	1
7	Mittelseite	07.179	1
8	Mittelseite	07.178	1
9	Oberboden	10.242	1
10	Zwischenboden	12.068	1
11	Unterboden	14.154	1
12	Zwischenboden	12.067	2
13	Zwischenboden	12.069	2
14	Glas Einlegeboden	E410041	2
15	Einlegeboden	16.102	4
16	Schubfront	92.003	2
17	Schubfront	92.004	2
18	Tür	92.204	2
19	Tür	92.310	2
20	Rückwand	28.106	2
21	Rückwand	28.105	2
22	Schubzarge links	31.043	2
23	Schubzarge rechts	32.043	2
24	Schubzarge quer	33.124	2
25	Schubzarge links	31.044	2
26	Schubzarge rechts	32.044	2
27	Schubzarge quer	33.136	2
28	Schubboden	19.069	4

Liste der Beschläge

A (E701000) 61x 8x30 	B (E701153) 30x 15 mm 	C (E701231) 46x 	D (E701149) 16x 12 mm 
E (E701010) 16x 6x40 	F (E700900) 90x 1,8x25 	G (E700000) 11x 4x15 	H (E704476) 
J (E702016) 16x 	K (E700140) 16x 6,3x13 	L (E700020) 28x 3,5x13 	
M (E703107) 4x 	N (E703108) 4x 		
O (E705040) 8x 	P (E705071) 8x 	Q (E710106) 4x 120 mm 	
R (E703408) 8x 	S (E710107) 4x 242 mm 		
T (E700060) 10x 3,5x17 	U (E700570) 16x M4x25 	V (E702008) 8x 	W (E709606) 12x 
X (E707616) 4x 334 mm 	Y (E706300) 4x 8x1,5 	a (E709318) 1x 	b (E700700) 2x 

1690

Serviceblatt, Bitte für evtl. Ersatzteilbestellung aufbewahren

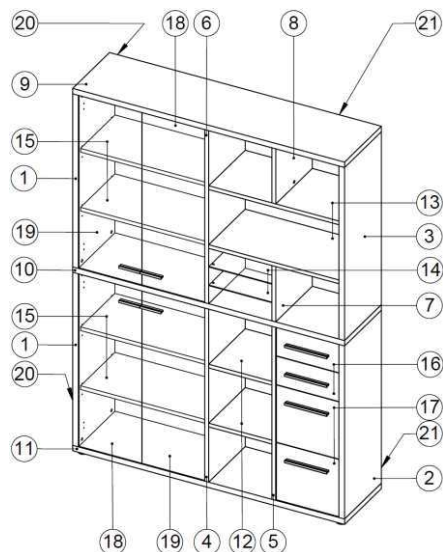

Sie haben sich für ein Qualitätsmöbel aus Deutscher Herstellung entschieden. Wir führen sehr umfangreiche Qualitätskontrollen nach ISO-Normen durch. Sollte der Artikel trotzdem Anlass zu einer Reklamation geben, bitten wir Sie die nachfolgenden Punkte zu beachten. So können wir Ihnen schnell und unbürokratisch helfen.

Ergänzen Sie die Artikelnummer durch die Farbnummer vom Etikett. Tragen Sie bitte auch die Kontrollnummer ein.

Artikelnummer 1 6 9 0 _ _ _ _

Kontrollnummer _ _ _ _ _

Zur Ersatzteilbestellung geben Sie bitte die Teilenummern an. (Bei Beschlägen die in Klammern stehenden Zahlen)

Geben Sie dieses Blatt an Ihr Möbelhaus weiter, damit wird eine schnellere Bearbeitung Ihrer Bestellung gewährleistet.

Service, please keep this sheet for possible order of replacement parts

Congratulations on your decision for a quality furniture Made in Germany. We do very extensive quality controls according to ISO norms. Should the article give cause to complaint anyway, we would ask you to pay attention to the following items, so we can assure quick and unbureaucratic help.

Please add the colour number - which is written on the label - to the code number and fill in the control number.

Code number: 1 6 9 0 _ _ _ _

Control number: _ _ _ _ _

For ordering a replacement part, please state the numbers of elements (in case of metal fittings the numbers in brackets).

Please pass this sheet on to your furniture shop. This ensures a quick treatment of your order.

Service après vente, veuillez garder cette feuille pour une commande éventuelle de pièces de rechange

Vous avez choisi, un meuble de qualité fabriqué en Allemagne. Nous vous félicitons pour votre décision. Nous réalisons des contrôles de qualités draconiens suivants les normes ISO. Malgré cela, si vous rencontrez un problème de SAV. Veuillez faire attention aux points suivants, pour une résolution rapide de ce problème.

Veuillez compléter le numéro d'article, avec le code couleur que vous trouverez sur l'étiquette collée sur le carton d'emballage. Veuillez également indiquer le numéro de contrôle.

Artikelnummer 1 6 9 0 _ _ _ _

Kontrollnummer _ _ _ _ _

Si vous commandez des pièces de rechange, veuillez indiquer les numéros des pièces.

Si vous commandez des pièces de quincaillerie, veuillez indiquer les références entre parenthèses.

Veuillez remettre ce document, au magasin où vous avez acheté ce meuble afin que votre

Teilleiste

Nummer	Bezeichnung	Teilenummer	Stück
1	Seite links	03.135	2
2	Seite rechts	05.135	1
3	Seite rechts	05.134	1
4	Mittelseite	07.175	1
5	Mittelseite	07.176	1
6	Mittelseite	07.177	1
7	Mittelseite	07.179	1
8	Mittelseite	07.178	1
9	Oberboden	10.242	1
10	Zwischenboden	12.068	1
11	Unterboden	14.154	1
12	Zwischenboden	12.067	2
13	Zwischenboden	12.069	2
14	Glas Einlegeboden	E410041	2
15	Einlegeboden	16.102	4
16	Schubfront	20.141	2
17	Schubfront	20.179	2
18	Tür	22.108	2
19	Tür	23.117	2
20	Rückwand	28.106	2
21	Rückwand	28.105	2
22	Schubzarge links	31.043	2
23	Schubzarge rechts	32.043	2
24	Schubzarge quer	33.124	2
25	Schubzarge links	31.044	2
26	Schubzarge rechts	32.044	2
27	Schubzarge quer	33.136	2
28	Schubboden	19.069	4

Liste der Beschläge

A (E701000) 61x 8x30 	B (E701153) 30x 15 mm 	C (E701231) 46x 	D (E701149) 16x 12 mm
E (E701010) 16x 6x40 	F (E700900) 90x 1,8x25 	G (E700000) 11x 4x15 	H (E704476)
J (E702016) 16x 	K (E700140) 16x 6,3x13 	L (E700020) 28x 3,5x13 	
M (E703107) 4x 		N (E703108) 4x 	
O (E705040) 8x 	P (E705071) 8x 	Q (E710106) 4x 120 mm 	
	R (E703408) 8x 	S (E710107) 4x 242 mm 	
T (E700060) 10x 3,5x17 	U (E700570) 16x M4x25 	V (E702008) 8x 	W (E709606) 12x
X (E707616) 4x 334 mm 		Y (E706300) 4x 8x1,5 	a (E709318) 1x
			b (E700700) 2x